

# INTERNATIONAL STANDARD



---

**Household and similar electrical appliances – Safety –  
Part 2-76: Particular requirements for electric fence energizers**



## THIS PUBLICATION IS COPYRIGHT PROTECTED

Copyright © 2018 IEC, Geneva, Switzerland

All rights reserved. Unless otherwise specified, no part of this publication may be reproduced or utilized in any form or by any means, electronic or mechanical, including photocopying and microfilm, without permission in writing from either IEC or IEC's member National Committee in the country of the requester. If you have any questions about IEC copyright or have an enquiry about obtaining additional rights to this publication, please contact the address below or your local IEC member National Committee for further information.

IEC Central Office  
3, rue de Varembe  
CH-1211 Geneva 20  
Switzerland

Tel.: +41 22 919 02 11  
[info@iec.ch](mailto:info@iec.ch)  
[www.iec.ch](http://www.iec.ch)

### About the IEC

The International Electrotechnical Commission (IEC) is the leading global organization that prepares and publishes International Standards for all electrical, electronic and related technologies.

### About IEC publications

The technical content of IEC publications is kept under constant review by the IEC. Please make sure that you have the latest edition, a corrigenda or an amendment might have been published.

#### IEC Catalogue - [webstore.iec.ch/catalogue](http://webstore.iec.ch/catalogue)

The stand-alone application for consulting the entire bibliographical information on IEC International Standards, Technical Specifications, Technical Reports and other documents. Available for PC, Mac OS, Android Tablets and iPad.

#### IEC publications search - [webstore.iec.ch/advsearchform](http://webstore.iec.ch/advsearchform)

The advanced search enables to find IEC publications by a variety of criteria (reference number, text, technical committee,...). It also gives information on projects, replaced and withdrawn publications.

#### IEC Just Published - [webstore.iec.ch/justpublished](http://webstore.iec.ch/justpublished)

Stay up to date on all new IEC publications. Just Published details all new publications released. Available online and also once a month by email.

#### Electropedia - [www.electropedia.org](http://www.electropedia.org)

The world's leading online dictionary of electronic and electrical terms containing 21 000 terms and definitions in English and French, with equivalent terms in 16 additional languages. Also known as the International Electrotechnical Vocabulary (IEV) online.

#### IEC Glossary - [std.iec.ch/glossary](http://std.iec.ch/glossary)

67 000 electrotechnical terminology entries in English and French extracted from the Terms and Definitions clause of IEC publications issued since 2002. Some entries have been collected from earlier publications of IEC TC 37, 77, 86 and CISPR.

#### IEC Customer Service Centre - [webstore.iec.ch/csc](http://webstore.iec.ch/csc)

If you wish to give us your feedback on this publication or need further assistance, please contact the Customer Service Centre: [sales@iec.ch](mailto:sales@iec.ch).



IEC 60335-2-76

Edition 3.0 2018-06

# INTERNATIONAL STANDARD



---

**Household and similar electrical appliances – Safety –  
Part 2-76: Particular requirements for electric fence energizers**

INTERNATIONAL  
ELECTROTECHNICAL  
COMMISSION

---

ICS 65.040.99

ISBN 978-2-8322-5808-8

**Warning! Make sure that you obtained this publication from an authorized distributor.**

## CONTENTS

FOREWORD.....	4
INTRODUCTION.....	7
1 Scope.....	8
2 Normative references.....	8
3 Terms and definitions .....	9
4 General requirement.....	13
5 General conditions for the tests.....	13
6 Classification.....	14
7 Marking and instructions .....	15
8 Protection against access to live parts .....	18
9 Starting of motor-operated appliances.....	18
10 Power input and current.....	18
11 Heating .....	18
12 Void .....	20
13 Leakage current and electric strength at operating temperature .....	20
14 Transient overvoltages.....	21
15 Moisture resistance .....	22
16 Leakage current and electric strength.....	22
17 Overload protection of transformers and associated circuits.....	23
18 Endurance.....	23
19 Abnormal operation .....	24
20 Stability and mechanical hazards .....	26
21 Mechanical strength.....	26
22 Construction.....	27
23 Internal wiring.....	31
24 Components.....	32
25 Supply connection and external flexible cords .....	32
26 Terminals for external conductors .....	32
27 Provision for earthing.....	33
28 Screws and connections .....	33
29 Clearances, creepage distances and solid insulation .....	33
30 Resistance to heat and fire .....	33
31 Resistance to rusting .....	34
32 Radiation, toxicity and similar hazards .....	34
Annexes .....	40
Annex A (informative) Routine tests .....	40
Annex B (normative) Appliances powered by rechargeable batteries that are recharged in the appliance.....	41
Annex S (normative) Battery-operated appliances powered by batteries that are non-rechargeable or not recharged in the appliance .....	43
Annex AA (informative) Circuit for the independent control of the switching speed of the major impulse-switching device .....	47

Annex BB (normative) Instructions for installation and connection of electric fences .....	48
BB.1 Instructions for electric animal fences .....	48
BB.2 Instructions for electric security fences not supplied from a security energizer group .....	50
BB.3 Instructions for electric security fences supplied from a security energizer group .....	52
Annex CC (informative) Installation of electric security fences .....	56
CC.1 General .....	56
CC.2 Location of electric security fence .....	56
CC.3 Prohibited zone for pulsed conductors .....	56
CC.4 Separation between electric fence and physical barrier .....	56
CC.5 Prohibited mounting .....	57
CC.6 Operation of electric security fence .....	57
Bibliography .....	60
Figure 101 – Schematic examples of type A energizers, type B energizers and type C energizers .....	35
Figure 102 – Schematic examples of the different types of type D energizers .....	36
Figure 103 – Current limited energizer characteristic limit line .....	37
Figure 104 – Type R security energizer group test configurations .....	38
Figure 105 – Type S security energizer group test configurations .....	39
Figure AA.1 – Circuit for the independent control of the switching speed of the major impulse-switching device .....	47
Figure BB.1 – Symbol for warning sign .....	55
Figure CC.1 – Prohibited area for pulse conductors .....	57
Figure CC.2 – Typical constructions where an electric security fence is exposed to the public .....	58
Figure CC.3 – Typical fence constructions where the electric security fence is installed in windows and skylights .....	59
Table 101 – Battery source impedance .....	19
Table 102 – Rated supply voltage maximum and minimum value multiplier factors .....	19
Table 103 – Supply voltage value test settings .....	20
Table 104 – Test supply sequence for different supply type .....	20
Table 105 – Additional test voltages .....	23
Table BB.1 – Minimum clearances from power lines for electric animal fences .....	49
Table BB.2 – Minimum clearances from power lines for electric security fences not supplied from a security energizer group .....	51
Table BB.3 – Minimum clearances from power lines for electric security fences supplied from a security energizer group .....	54

# INTERNATIONAL ELECTROTECHNICAL COMMISSION

## HOUSEHOLD AND SIMILAR ELECTRICAL APPLIANCES – SAFETY –

### Part 2-76: Particular requirements for electric fence energizers

#### FOREWORD

- 1) The International Electrotechnical Commission (IEC) is a worldwide organization for standardization comprising all national electrotechnical committees (IEC National Committees). The object of IEC is to promote international co-operation on all questions concerning standardization in the electrical and electronic fields. To this end and in addition to other activities, IEC publishes International Standards, Technical Specifications, Technical Reports, Publicly Available Specifications (PAS) and Guides (hereafter referred to as “IEC Publication(s)”). Their preparation is entrusted to technical committees; any IEC National Committee interested in the subject dealt with may participate in this preparatory work. International, governmental and non-governmental organizations liaising with the IEC also participate in this preparation. IEC collaborates closely with the International Organization for Standardization (ISO) in accordance with conditions determined by agreement between the two organizations.
- 2) The formal decisions or agreements of IEC on technical matters express, as nearly as possible, an international consensus of opinion on the relevant subjects since each technical committee has representation from all interested IEC National Committees.
- 3) IEC Publications have the form of recommendations for international use and are accepted by IEC National Committees in that sense. While all reasonable efforts are made to ensure that the technical content of IEC Publications is accurate, IEC cannot be held responsible for the way in which they are used or for any misinterpretation by any end user.
- 4) In order to promote international uniformity, IEC National Committees undertake to apply IEC Publications transparently to the maximum extent possible in their national and regional publications. Any divergence between any IEC Publication and the corresponding national or regional publication shall be clearly indicated in the latter.
- 5) IEC itself does not provide any attestation of conformity. Independent certification bodies provide conformity assessment services and, in some areas, access to IEC marks of conformity. IEC is not responsible for any services carried out by independent certification bodies.
- 6) All users should ensure that they have the latest edition of this publication.
- 7) No liability shall attach to IEC or its directors, employees, servants or agents including individual experts and members of its technical committees and IEC National Committees for any personal injury, property damage or other damage of any nature whatsoever, whether direct or indirect, or for costs (including legal fees) and expenses arising out of the publication, use of, or reliance upon, this IEC Publication or any other IEC Publications.
- 8) Attention is drawn to the Normative references cited in this publication. Use of the referenced publications is indispensable for the correct application of this publication.
- 9) Attention is drawn to the possibility that some of the elements of this IEC Publication may be the subject of patent rights. IEC shall not be held responsible for identifying any or all such patent rights.

This part of International Standard IEC 60335 has been prepared by subcommittee 61H: Safety of electrically-operated farm appliances, of IEC technical committee 61: Safety of household and similar electrical appliances.

This third edition cancels and replaces the second edition published in 2002, Amendment 1:2006 and Amendment 2:2013. This edition constitutes a technical revision.

This edition includes the following significant technical changes with respect to the previous edition:

- the text has been aligned with Edition 5.2 of Part 1;
- additional requirements for security fence energizers have been introduced (Clauses 3, 7, 19, 22, Figures and Annex BB);
- specific requirements for battery operated energizers have been moved to Annex S.

The text of this International Standard is based on the following documents:

FDIS	Report on voting
61H/366/FDIS	61H/367/RVD

Full information on the voting for the approval of this International Standard can be found in the report on voting indicated in the above table.

This document has been drafted in accordance with the ISO/IEC Directives, Part 2.

A list of all parts in the IEC 60335 series, published under the general title *Household and similar electrical appliances – Safety*, can be found on the IEC website.

This Part 2 is to be used in conjunction with the latest edition of IEC 60335-1 and its amendments. It was established on the basis of the fifth edition (2010) of that standard.

NOTE 1 When “Part 1” is mentioned in this standard, it refers to IEC 60335-1.

This Part 2 supplements or modifies the corresponding clauses in IEC 60335-1, so as to convert that publication into the IEC standard: Safety requirements for electric fence energizers.

When a particular subclause of Part 1 is not mentioned in this Part 2, that subclause applies as far as is reasonable. When this standard states “addition”, “modification” or “replacement”, the relevant text in Part 1 is to be adapted accordingly.

NOTE 2 The following numbering system is used:

- subclauses, tables and figures that are numbered starting from 101 are additional to those in Part 1;
- unless notes are in a new subclause or involve notes in Part 1, they are numbered starting from 101, including those in a replaced clause or subclause;
- additional Annexes are lettered AA, BB, etc.

NOTE 3 The following print types are used:

- requirements: in roman type
- *test specifications: in italic type*
- notes: in small roman type.

Words in **bold** in the text are defined in Clause 3. When a definition concerns an adjective, the adjective and associated noun are also in bold.

NOTE 4 The attention of National Committees is drawn to the fact that equipment manufacturers and testing organizations may need a transitional period following publication of a new, amended or revised IEC publication in which to make products in accordance with the new requirements and to equip themselves for conducting new or revised tests.

It is the recommendation of the committee that the content of this publication be adopted for implementation nationally not earlier than 12 months or later than 36 months from the date of publication.

The following differences exist in the countries indicated below:

6.101: Only energy limited energizers are allowed (All EU and EFTA counties).

The committee has decided that the contents of this document will remain unchanged until the stability date indicated on the IEC website under "<http://webstore.iec.ch>" in the data related to the specific document. At this date, the document will be

- reconfirmed,
- withdrawn,
- replaced by a revised edition, or
- amended.

A bilingual version of this publication may be issued at a later date.

**IMPORTANT – The 'colour inside' logo on the cover page of this publication indicates that it contains colours which are considered to be useful for the correct understanding of its contents. Users should therefore print this document using a colour printer.**

## INTRODUCTION

It has been assumed in the drafting of this International Standard that the execution of its provisions is entrusted to appropriately qualified and experienced persons.

This standard recognizes the internationally accepted level of protection against hazards such as electrical, mechanical, thermal, fire and radiation of appliances when operated as in normal use taking into account the manufacturer's instructions. It also covers abnormal situations that can be expected in practice and takes into account the way in which electromagnetic phenomena can affect the safe operation of appliances.

This standard takes into account the requirements of IEC 60364 as far as possible so that there is compatibility with the wiring rules when the appliance is connected to the supply mains. However, national wiring rules may differ.

If an appliance within the scope of this standard also incorporates functions that are covered by another part 2 of IEC 60335, the relevant part 2 is applied to each function separately, as far as is reasonable. If applicable, the influence of one function on the other is taken into account.

NOTE 1 Throughout this publication, when "Part 1" is mentioned, it refers to IEC 60335-1.

When a part 2 standard does not include additional requirements to cover hazards dealt with in Part 1, Part 1 applies.

NOTE 2 This means that the technical committees responsible for the part 2 standards have determined that it is not necessary to specify particular requirements for the appliance in question over and above the general requirements.

This standard is a product family standard dealing with the safety of appliances and takes precedence over horizontal and generic standards covering the same subject.

NOTE 3 Horizontal and generic standards covering a hazard are not applicable since they have been taken into consideration when developing the general and particular requirements for the IEC 60335 series of standards. For example, in the case of temperature requirements for surfaces on many appliances, generic standards, such as ISO 13732-1 for hot surfaces, are not applicable in addition to Part 1 or part 2 standards.

# HOUSEHOLD AND SIMILAR ELECTRICAL APPLIANCES – SAFETY –

## Part 2-76: Particular requirements for electric fence energizers

### 1 Scope

This clause of Part 1 is replaced by the following.

This part of IEC 60335 deals with the safety of **electric fence energizers**, the **rated voltage** of which is not more than 250 V and by means of which **fence** wires in agricultural, domestic or feral animal control **fences** and **security fences** may be electrified or monitored.

NOTE 101 Examples of **electric fence energizers** coming within the scope of this standard are:

- **mains-operated energizers**;
- **battery-operated electric fence energizers suitable for connection to the mains**, as shown in Figure 101 and Figure 102;
- **electric fence energizers** operated by non-rechargeable batteries either incorporated or separate.

This standard does not in general take into account

- the use of appliances by young children or infirm persons without supervision;
- the playing with appliances by young children.

NOTE 102 Attention is drawn to the fact that

- for appliances intended to be used on board ships or aircraft, additional requirements can be necessary;
- in many countries, additional requirements are specified by the national health authorities, the national authorities responsible for the protection of labour, the national water supply authorities and similar authorities.

NOTE 103 This standard does not apply to

- electromagnetically coupled animal trainer collars;
- appliances intended to be used in locations where special conditions prevail, such as the presence of a corrosive or explosive atmosphere (dust, vapour or gas);
- separate battery chargers (IEC 60335-2-29);
- electric fishing machines (IEC 60335-2-86);
- electric animal-stunning equipment (IEC 60335-2-87);
- appliances for medical purposes (IEC 60601).

### 2 Normative references

This clause of Part 1 is applicable except as follows.

*Addition:*

IEC 60068-2-52:2017, *Environmental testing – Part 2: Tests – Test Kb: Salt mist, cyclic (sodium chloride solution)*

IEC 60320-3, *Appliance couplers for household and similar general purposes – Part 3: Standard sheets and gauges*

ISO 3864-1, *Graphical symbols – Safety colours and safety signs – Part 1: Design principles for safety signs and safety markings*

### 3 Terms and definitions

This clause of Part 1 is applicable except as follows.

#### 3.1 Definitions relating to physical characteristics

##### 3.1.1 Addition:

Note 1 to entry: For **type D energizers**, the **rated voltage** of the **energizer** is the **rated voltage** for battery supply.

*Replacement:*

##### 3.1.9 normal operation

operation of the appliance under the following conditions: the **electric fence energizer** is operated as in normal use when connected to the supply, with no load connected to the output terminals

##### 3.1.101 prospective peak voltage

peak output voltage of the impulse generator specified in Clause 14 that would be obtained with the **energizer** not connected to the test circuit

##### 3.1.102 rated voltage for battery supply

voltage for battery supply, for **type A energizers**, **type B energizers**, **type C energizers** and **type D energizers** assigned to the **energizer** by the manufacturer

##### 3.1.103 rated voltage range for battery supply

voltage range for battery supply, for **type A energizers**, **type B energizers**, **type C energizers** and **type D energizers** assigned to the **energizer** by the manufacturer, expressed by its lower and upper limits

##### 3.1.104 impulse duration

duration of that part of the impulse that contains 95 % of the overall energy and is the shortest interval of integration of  $I^2(t)$  that gives 95 % of the integration of  $I^2(t)$  over the total impulse

Note 1 to entry:  $I(t)$  is the impulse current as a function of time.

##### 3.1.105 output current

RMS value of the **output current** per impulse calculated over the impulse duration

#### 3.5 Definitions relating to types of appliances

##### 3.5.101 electric fence energizer

appliance that is intended to deliver periodically voltage impulses to a **fence** connected to it

Note 1 to entry: **Electric fence energizers** are hereinafter also referred to as **energizers**.

##### 3.5.102 mains-operated energizer energizer designed for direct connection to the mains

**3.5.103****battery-operated energizer suitable for connection to the mains energizer**

- operated by batteries and having, or being designed for connection to, facilities for charging these batteries from the mains, or
- designed for operation from the mains and from batteries

**3.5.104****type A energizer**

**battery-operated energizer suitable for connection to the mains** consisting of an impulse generating circuit, a battery charging circuit and a battery, the impulse generating circuit being connected to the mains or the battery when the energizer is in operation

Note 1 to entry: **Type A energizers** are shown schematically in Figure 101.

**3.5.105****type B energizer**

**battery-operated energizer suitable for connection to the mains** consisting of an impulse generating circuit, a battery charging circuit and a battery, the impulse generating circuit being connected to the battery and disconnected from the battery charging circuit and the mains when the **energizer** is in operation.

Note 1 to entry: For recharging the battery, the impulse generating circuit is disconnected and rendered inoperable.

Note 2 to entry: **Type B energizers** are shown schematically in Figure 101.

**3.5.106****type C energizer**

**battery-operated energizer suitable for connection to the mains** consisting of an impulse generating circuit and a battery, the impulse generating circuit being connected to the mains or the battery when the energizer is in operation, and where it is necessary to remove the battery to recharge it using a battery charger or, in the case of a non-rechargeable battery, to replace it with a new battery

Note 1 to entry: **Type C energizers** are shown schematically in Figure 101.

**3.5.107****type D energizer**

**battery-operated energizer suitable for connection to the mains** consisting of an impulse generating circuit intended to be powered by a battery, or a **detachable supply unit**, when the **energizer** is in operation. The impulse generating circuit or the battery may be connected to a **detachable supply unit** with or without incorporated battery charging circuitry for recharging the battery when the **energizer** is in operation.

Note 1 to entry: Examples of **Type D energizers** are shown schematically in Figure 102.

**3.5.108****battery-operated energizer**

**energizer** deriving its energy solely from batteries or other sources of energy and not designed for connection to the mains

**3.5.109****security electric fence energizer**

**energizer** containing **fence circuits** that are intended to periodically deliver voltage impulses into **electric security fences**

Note 1 to entry: A **security electric fence energizer** is hereinafter also referred to as a **security energizer**.

**3.5.110****independently timed security energizer**

**security energizer** that includes an internal **impulse timing signal source** to set the timing of the periodic voltage impulses it delivers to an **electric security fence**

Note 1 to entry: An **independently timed security energizer** is hereinafter also referred to as **an independent security energizer**.

**3.5.111****dependently timed security energizer**

**security energizer** that is dependent on an external **impulse timing signal** to set the timing of the periodic voltage impulses it delivers to an **electric security fence**

Note 1 to entry: A **dependently timed security energizer** is hereinafter also referred to as **dependent security energizer**.

Note 2 to entry: Some types of **security energizer** may be configured either as an **independent security energizer** or a **dependent security energizer** at the time of installation.

**3.5.112****security energizer group**

one or two **security energizers** with a group total of two **fence circuits** used to supply adjacent **electric security fences** in a **security energizer fence system** that allows the two **fence circuits** to be contacted at the same time

Note 1 to entry: The **fence circuits** in a **security energizer group** may be galvanically connected.

**3.5.113****type R security energizer**

**security energizer** with one or two **fence circuits** that is suitable for use in a **type R security energizer group**

**3.5.114****type R security energizer group**

**security energizer group** containing only **type R security energizers**

**3.5.115****type S security energizer**

**security energizer** with one or two **fence circuits** that is suitable for use in a **type S security energizer group**

**3.5.116****type S security energizer group**

**security energizer group** containing at least one **type S security energizer**

Note 1 to entry: A **type S security energizer group** may contain a **type R security energizer**.

**3.6 Definitions relating to parts of an appliance****3.6.3 Addition:**

Note 101 to entry: It also includes terminals for the connection of the battery and other metal parts in a battery compartment that become accessible when replacing batteries even with the aid of a **tool**.

*Replacement:*

**3.6.4****live part**

conductive part that may cause an electric shock

### **3.6.101 fence circuit**

all conductive parts or components within an **energizer**, that are connected or intended to be connected galvanically to the output terminals

### **3.6.102 security energizer impulse timing signal**

signal that is used to determine the timing of the periodic voltage impulses delivered by a **security energizer** to an **electric security fence**

Note 1 to entry: A **security energizer impulse timing signal** is hereinafter also referred to as an **impulse timing signal**.

Note 2 to entry: Examples of a **security energizer impulse timing signal** include wired (RS-485), wired with latency (internet clock, secure TCP/IP), wireless with latency (LAN, PAN), optical, GPS.

### **3.6.103 impulse timing signal source**

signal source that generates the **impulse timing signal** required by a **dependent security energizer** to set the timing of the periodic voltage impulses it delivers to an **electric security fence**

Note 1 to entry: An **impulse timing signal source** may be used by one or more **dependent security energisers**.

Note 2 to entry: An example of an **impulse timing signal source** is an impulse signal from an adjacent **electric security fence** that is powered by an **independent security energizer** that belongs to the same **security energizer fence system**.

Note 3 to entry: An impulse signal from an adjacent **electric security fence** powered by an **independent security energizer** not belonging to the same **security energizer fence system** is not an example of a possible **impulse timing signal source**.

## **3.8 Definitions relating to miscellaneous matters**

### **3.8.101 standard load**

load consisting of a non-inductive resistor of  $500 \Omega \pm 2,5 \Omega$  and a variable resistor that is adjusted so as to maximize the energy per impulse or **output current** in the  $500 \Omega$  resistor, as applicable

Note 1 to entry: The variable resistor is connected in series or parallel with the  $500 \Omega$  resistor, whichever gives the more unfavourable result.

### **3.8.102 earth electrode**

metal structure that is driven into the ground near an **energizer** and connected electrically to the output earth terminal of the **energizer**, and that is independent of other earthing arrangements

### **3.8.103 pulsed conductors**

conductors that are subjected to high voltage pulses by the **energizer**

### **3.8.104 connecting lead**

electric conductor, used to connect the **energizer** to the **electric fence** or the **earth electrode**

### **3.8.105 fence**

barrier for animals or for security purposes, comprising one or more conductors, such as metal wires, rods or rails

**3.8.106****electric fence**

barrier that includes one or more electric conductors, insulated from earth, to which electric pulses are applied by an **energizer**

**3.8.107****electric animal fence**

**electric fence** used to contain animals within or exclude animals from a particular area

**3.8.108****electric security fence**

**fence** used for security purposes that comprises an **electric fence** and a physical barrier electrically isolated from the **electric fence**

**3.8.109****physical barrier**

barrier not less than 1,5 m high intended to prevent inadvertent contact with the **pulsed conductors** of the **electric fence**

Note 1 to entry: **Physical barriers** are typically constructed from vertical sheeting, rigid vertical bars, rigid mesh, rods or chain-wire mesh.

**3.8.110****public access area**

any area where persons are protected from inadvertent contact with **pulsed conductors** by a **physical barrier**

**3.8.111****secure area**

area where a person is not separated from **pulsed conductors** below 1,5 m by a **physical barrier**

**3.8.112****security energizer fence system**

**electric security fence** installation where the **fences** are energized by one or more **security energizers** containing one or more **security energizer groups** that can be **type R security energizer groups** or **type S security energizers groups**

Note 1 to entry: An **independent impulse timing signal source** used in a **security energizer fence system** may be used to set the timing of **dependent security energizers** in multiple **security energizer groups**.

## 4 General requirement

This clause of Part 1 is applicable.

## 5 General conditions for the tests

This clause of Part 1 is applicable except as follows.

### 5.2 Modification:

*Replace the test specification by the following:*

*The tests are made on two **energizers** as delivered, one being subjected to all the tests with the exception of that of Clause 18, and the other to the tests of 22.108 and Clause 18. However, the tests of Clauses 22 to 28 may be made on separate samples.*

*For **type A energizers** and **type C energizers**, an additional sample is required for the test of Clause 18.*

*Addition:*

NOTE 101 Where **electronic circuits**, **electronic components** or other devices are normally encapsulated, specially prepared samples can be used for the tests of 19.11 and 19.101.

### 5.3 *Addition:*

*The measurements of 22.108 shall be carried out before the tests of Clause 14.*

*If any **electronic component** has been damaged during the tests of Clause 14, the tests of Clause 19 are made twice, once before and once after the damaged **electronic components** have been replaced by new **electronic components**.*

### 5.5 *Addition:*

*The **energizer** is mounted in a normal position such that the deviation from the position for which it is designed does not exceed 15°. However, if the **energizer** is provided with means for adjustment to the normal position, such as a spirit level, the **energizer** shall be adjusted to within ±2° of the normal position.*

*The earthing terminal of the **fence circuit** is connected to earth. However, if there is no indication as to which of the output terminals is to be connected to earth, the terminal that gives the most unfavourable result is earthed.*

### 5.8.1 *Addition:*

*For **type A energizers**, **type B energizers**, **type C energizers** and **type D energizers** where the terminals for the connection of the battery have no indication of polarity, the more unfavourable polarity of the voltage source replacing the battery shall be applied.*

*For **mains-operated energizers** and **battery-operated energizers suitable for connection to the mains**, the reference source impedance of the mains supply shall be  $0,4 \Omega + j0,25 \Omega$ .*

**5.101** *All **energizers** are tested as **motor-operated appliances**.*

## 6 Classification

This clause of Part 1 is applicable except as follows.

### 6.1 *Replacement:*

**Mains-operated energizers** and **battery-operated energizers suitable for connection to the mains** shall be **class II** with respect to protection against electric shock.

*Compliance is checked by inspection and by the relevant tests.*

### 6.2 *Addition:*

**Energizers** shall be of at least IPX4.

**6.101 Energizers** are classified as being either **energy limited energizers** or **current limited energizers**.

*Compliance is checked by the appropriate tests.*

## 7 Marking and instructions

This clause of Part 1 is applicable except as follows.

### 7.1 Addition:

**Type A energizers, type B energizers and type C energizers** shall be marked with the **rated voltage for battery supply** or **rated voltage range for battery supply**, in volts.



**Energy limited energizers** that are marked with a maximum energy/impulse exceeding 5 J shall also be marked with the corresponding load resistance at which maximum energy/impulse is obtained.

**Energizers** shall be marked with symbol ISO 7000-0790 (2004-01).

**Type R security energizers** shall be marked with symbol IEC 60417-6406 (2018-02).

**Type S security energizers** shall be marked with symbol IEC 60417-6407 (2018-02).

### 7.6 Addition:

	[symbol IEC 60417-5036 (2002-10)]	dangerous voltage
	[symbol IEC 60417-5017 (2006-08)]	earth; ground
	[symbol IEC 60417-6406 (2018-02)]	time synchronized type R security energizer
	[symbol IEC 60417-6407 (2018-02)]	time synchronized type S security energizer

The symbols for output (**fence**) and output (earth) shall be in accordance with symbols IEC 60417-5036 (2002-10) and IEC 60417-5017 (2006-08) respectively.

### 7.12 Addition:

Instructions for battery-operated energizers suitable for connection to the mains shall

- include a warning against using non-rechargeable batteries while the **energizer** is powered by mains;
- state that, during charging, vented rechargeable-batteries shall be placed in a well-ventilated area.

Instructions for **type D energizers** shall list accessories made available by the manufacturer.

### 7.14 Addition:

The outer diameter of the circle of symbol IEC 60417-6406 (2018-02) and symbol IEC 60417-6407 (2018-02) shall be at least 15 mm.

**7.101** Unless the correct mode of connection is obvious or irrelevant, the output terminals of the **energizer**, other than dedicated output earth terminals, shall be clearly and indelibly identified using symbol IEC 60417-5036 (2002-10). Dedicated output earth terminals shall be clearly and indelibly identified using symbol IEC 60417-5017 (2006-08).

Where alternative output terminals are provided, they shall be similarly marked, or marked with the words FULL POWER, REDUCED POWER or REDUCED VOLTAGE, as appropriate.

If a switch to control the output energy is provided, the various positions of the switch shall be marked with the appropriate symbols, or with the words FULL POWER, REDUCED POWER or REDUCED VOLTAGE, as appropriate.

The height of characters in the marking shall not be less than that given by an 18 point font and the symbols shall have a height of at least 6 mm.

*Compliance is checked by inspection and measurement.*

**7.102** For **battery-operated energizers suitable for connection to the mains**, the supply terminals for connection of the battery shall be clearly indicated by symbol IEC 60417-5005 (2002-10) for positive polarity, and by symbol IEC 60417-5006 (2002-10) for negative polarity, unless the polarity is irrelevant.

*Compliance is checked by inspection.*

**7.103 Energizers** shall be supplied with instructions that contain the information given in Annex BB regarding

- the installation of **electric fences**;
- the means of connecting the **energizer** to the **electric fence**.

Such information shall contain the substance of the wording given in Clause BB.1 (electric animal fences), Clause BB.2 (electric security fences not supplied from a security energizer group) or Clause BB.3 (electric security fences supplied from a security energizer group), as appropriate.

**Energizers** intended for use with **electric security fences** may also be supplied with the information given in Annex CC.

*Compliance is checked by inspection.*

**7.104** The instructions for a **security energizer** that is suitable for use in a **security energizer group** shall contain the substance of the following:

- only type R security energizers or type S security energizers can be used in security energizer groups;
- a type S security energizer shall not be used in a type R security energizer group;
- a type R security energizer may be used in a type S security energizer group;
- identification of the model or type reference of security energizers that are permitted to be used in the security energizer group;
- security energizer groups shall only include security energizers that are identified in the instructions;
- the permitted configurations and connections of security energizers that may be used in the security energizer groups;

- identification of the model or type reference of the device producing the impulse timing signal source that is suitable for use in the security energizer group;
- a security energizer fence system must be configured and installed by, or under the responsibility of an authorized installer;
- a security energizer fence system shall be serviced and maintained by, or under the responsibility of an authorized installer;
- after installation, a label shall be attached to each energizer in a security energizer group that provides the authorized installer's name, contact details and the installation date;
- after servicing, a label shall be attached to each energizer in a security energizer group that provides the authorized installer's name, contact details and the service date;
- an authorised installer is a person suitably trained by the manufacturer to be able to safely configure, install and maintain a **security energizer fence system** on the basis of professional training, knowledge, experience and familiarity of the relevant equipment.

The instructions for a **security energizer** that is suitable for use in a **security energizer group** shall

- provide an explanation of the hazards of not using **security energizer groups** in locations where two electric security fences can be contacted at the same time;
- provide an explanation of the hazards of not correctly configuring a **security energizer** when used in a **security energizer group**. These hazards include:
  - receiving a too large impulse;
  - receiving consecutive two impulses that are not spaced apart enough in time;
  - touching an electric security fence whose isolation from the supply mains has been compromised;
- explain the meaning of the time synchronized symbols IEC 60417-6406 (2018-02) and IEC 60417-6407 (2018-02), if they are used;
- provide a general explanation of the safety objectives and technical requirements of a **security energizer group** that can be properly understood by an authorized installer;
- provide a general explanation of the safety objectives and technical requirements of a **security energizer fence system** that can be correctly understood by an authorized installer.

The front section of the instructions shall include the substance of the following warnings:

### **IMPORTANT WARNINGS**

**WARNING:** These instructions must be fully complied with in every respect

**WARNING:** A security energizer group must be used at any point where two electric security fences can be contacted by a person at the same time

**WARNING:** Give special attention to the correct type selection and connection of security energizers used in a security energizer group

**WARNING:** A security energizer fence system should be checked for safety by an authorized installer prior to operation

**DANGER:** Failure to comply fully with the instructions could lead to a fatal electric shock

*Compliance is checked by inspection.*

## 8 Protection against access to live parts

This clause of Part 1 is applicable except as follows.

### 8.1.4 Addition:

*The means for the connection of the **fence** is not considered to be a **live part**.*

## 9 Starting of motor-operated appliances

This clause of Part 1 is not applicable.

## 10 Power input and current

This clause of Part 1 is applicable except as follows.

**10.101** For **energy limited energizers** that are marked with a maximum energy/impulse exceeding 5 J, the value so marked shall not deviate from that delivered by more than  $\pm 10\%$  and the load resistance at which it is obtained shall not deviate from the value marked on the **energizer** by more than  $\pm 5\%$ .

*Compliance is checked by the following test.*

*The **energizer** is supplied at **rated voltage** or **rated voltage for battery supply**, as appropriate, under conditions of **normal operation** but with a variable resistive load connected across its output terminals.*

*The energy per impulse dissipated in the resistive load connected across the **energizer** output terminals is measured using the measuring arrangement described in 22.108. The resistive load value is measured after it is adjusted to maximize the energy per impulse measured.*

## 11 Heating

This clause of Part 1 is applicable except as follows.

### 11.2 Addition:

*For **type A energizers** when connected for mains supply, **type D energizers** when connected for battery charging supply and **type B energizers** when connected for mains supply with battery charge operation, a battery of the largest capacity for which the **energizer** is designed is connected to the terminals for the connection of the battery supply. Before starting the test, the battery is discharged to such an extent that the voltage delivered by the battery does not exceed 0,75 times its nominal value.*

### 11.5 Replacement:

*The **energizer** is operated under **normal operation**, supplied as follows.*

*A **mains-operated energizer** is supplied with the most unfavourable supply voltage between 0,85 and 1,1 times **rated voltage**.*

**Type A energizers and type C energizers**, when they are connected for mains supply, are supplied with the most unfavourable supply voltage between 0,85 and 1,1 times **rated voltage**.

A **type B energizer**, when it is connected for mains supply with battery charge operation, is supplied with the most unfavourable supply voltage between 0,85 and 1,1 times **rated voltage**.

**Type A energizers, type B energizers, type C energizers and type D energizers**, when they are connected for battery supply, are supplied at the terminals for the connection of the battery with the most unfavourable supply voltage between

- 0,55 and 1,1 times **rated voltage for battery supply**, if the **energizer** can be used with non-rechargeable batteries;
- 0,75 and 1,1 times **rated voltage for battery supply**, if the **energizer** is designed for use with rechargeable batteries only.

The values specified in Table 101 for the internal resistance per cell of the battery shall be taken into account.

**Table 101 – Battery source impedance**

Supply to the terminals for the connection of the battery	Internal resistance per cell $\Omega$	
	Non-rechargeable batteries	Rechargeable batteries
1,1 times <b>rated voltage for battery supply</b>	0,08	0,001 2
1,0 times <b>rated voltage for battery supply</b>	0,10	0,001 5
0,75 times <b>rated voltage for battery supply</b>	0,75	0,006 0
0,55 times <b>rated voltage for battery supply</b>	2,00	–

NOTE When determining the internal resistance of a battery, two or more cells connected in parallel are considered to be one cell.

**Type D energizers** are supplied from a source incorporating a series resistance of 1  $\Omega$  and having the form of

- a half-wave rectified sine-wave with an RMS value equal to the **rated voltage for battery supply**,
- a full-wave rectified sine-wave with an RMS value equal to the **rated voltage for battery supply**,

whichever is the more unfavourable.

**Security energizers** used in a **security energizer group** shall be tested together in any permitted configuration and connection that may be allowed in the group.

The maximum and minimum supply voltage values are set in accordance with Table 102 using multiplier factors based on the **rated voltage** or **rated voltage range** of the appliance.

**Table 102 – Rated supply voltage maximum and minimum value multiplier factors**

Supply voltage value	Mains	Battery (rechargeable)	Battery (non-rechargeable)
Minimum	0,85	0,75	0,55
Maximum	1,1	1,1	1,1

The **security energizer** feeding the first **fence circuit** is operated, for a given supply voltage type, on three supply voltage value settings in turn, the minimum value, the maximum value and one freely selected value between the minimum and maximum values, while the **security energizer** feeding the second **fence circuit** is supplied, for a given supply voltage type, with any supply voltage varied between the maximum and minimum values that is selected to produce the most unfavourable result.

The above tests are repeated, but with the first and second **security energizer** settings reversed. Refer to Table 103.

**Table 103 – Supply voltage value test settings**

<b>Test</b>	<b>First fence circuit supply</b>	<b>Second fence circuit supply</b>
1	Maximum value	Selected for worst case
2	Minimum value	Selected for worst case
3	Freely selected value	Selected for worst case
4	Selected for worst case	Maximum value
5	Selected for worst case	Minimum value
6	Selected for worst case	Freely selected value

The above tests are repeated for both mains and battery supply voltage operation as applicable in accordance with Table 104.

**Table 104 – Test supply sequence for different supply type**

<b>Test</b>	<b>First fence circuit supply</b>	<b>Second fence circuit supply</b>
MM	Mains	Mains
MB	Mains	Battery
BM	Battery	Mains
BB	Battery	Battery

NOTE 101 For a typical **security energizer group**, based on two **security energizers** that both can run on mains or rechargeable battery, there would be a total of twenty four tests performed. However in some cases where only mains or battery operation is indicated, the number can be less or in the case where a non-rechargeable battery option is also included, the number of tests could be doubled.

**11.7 Replacement:**

The **energizer** is operated until steady conditions are established.

**12 Void**

**13 Leakage current and electric strength at operating temperature**

This clause of Part 1 is applicable except as follows.

**13.1 Modification:**

Compliance is checked by the tests of 13.2 and 13.3 for **mains-operated energizers** and **battery-operated energizers suitable for connection to the mains only**.

*Addition:*

The **energizer** is operated under **normal operation** when supplied as specified in 11.5 for mains operation.

## 14 Transient overvoltages

**14.101 Energizers** shall be resistant to atmospheric surges entering from the **fence**.

Compliance is checked by the tests of 14.102 to 14.104 for **mains-operated energizers** and **battery-operated energizers suitable for connection to the mains**.

NOTE The value of  $U_0$  is the peak value of the **energizer** output voltage obtained during the test of 22.111.

Unless otherwise specified, during the tests, no disruptive discharges shall occur but surge protection devices are allowed to operate.

**Mains-operated energizers** and **battery-operated energizers suitable for connection to the mains** are fixed to a metal plate having dimensions that are at least 150 mm in excess of those of the orthogonal projection of the **energizer** on the plate, and are then installed as in normal use.

The tests are made by means of an impulse generator producing positive and negative full lightning impulses having a front time of 1,2  $\mu$ s and a time to half-value of 50  $\mu$ s, the tolerances being

- $\pm 5$  % for the peak value;
- $\pm 30$  % for the front time;
- $\pm 20$  % for the time to half-value.

Small oscillations in the impulse are allowed, provided their amplitude near the peak of the impulse is less than 5 % of the peak value. For oscillations during the first half of the front time, amplitudes up to 10 % of the peak value are allowed.

The shape of the impulses is adjusted with the **energizer** connected to the impulse generator. The adjustment shall be made at approximately 50 % of the test voltage specified. If, for the test of 14.104, it is not possible to obtain the correct shape of the impulses, it is only necessary to ascertain that the front time has the required value at approximately 50 % of the **prospective peak voltage** specified.

The impulse generator to be used for the tests shall have an energy content of at least 125 J at the test voltage.

**14.102** Five positive and five negative impulses, each having a **prospective peak voltage** of  $2U_0$  but not less than 25 kV, are applied between

- the output terminals and AC input terminals connected together and the metal plate, for **mains-operated energizers** and **type A energizers**, **type B energizers** and **type C energizers**,
- the output terminals and the metal plate, for **type D energizers**,

the interval between consecutive impulses being at least 10 s.

**Type D energizers** are further tested as follows.

Each specified **detachable supply unit** is connected to the impulse generating circuit of the **energizer** in turn. The impulse voltages are applied between the **energizer** output terminals and the AC input terminals of the specified **detachable supply unit** connected together and the metal plate.

**14.103** Five positive and five negative impulses, each having a **prospective peak voltage** of  $2U_0$  but not less than 25 kV, are applied between the output terminals connected together and

- the AC input terminals connected together, for **mains-operated energizers** and **type A energizers**, **type B energizers** and **type C energizers**,
- the terminals for connection of the external battery charger, for **type D energizers**,

the interval between consecutive impulses being at least 10 s.

If, during this test, a surge protection device operates, the test is repeated with the surge protection device rendered inoperative. During the repeat test no disruptive discharges are allowed.

If the **energizer** has more than one **fence circuit**, each **fence circuit** is subjected to this test in turn, the other **fence circuits** being open-circuited.

**Type D energizers** are further tested as follows.

Each specified **detachable supply unit** is connected to the impulse generating circuit of the **energizer** in turn. The impulse voltages are applied between the **energizer** output terminals and the AC input terminals of the specified **detachable supply unit** connected together and the metal plate.

**14.104** Five positive and five negative impulses, each having a **prospective peak voltage** of  $2U_0$  but not less than 25 kV, are applied between the output terminals, the interval between the impulses being at least 10 s. The input terminals are open-circuited. For **type D energizers**, the input terminals of the impulse generating circuit are open-circuited.

## 15 Moisture resistance

This clause of Part 1 is applicable.

## 16 Leakage current and electric strength

This clause of Part 1 is applicable except as follows.

### 16.1 Modification:

Compliance is checked by the tests of 16.2, 16.3 and 16.101 for **mains-operated energizers** and **battery-operated energizers suitable for connection to the mains**.

### 16.2 Modification:

The test voltage is the upper limit of the voltage in 11.5.

### 16.3 Addition:

Other values of the test voltages and the points of application are shown in Table 105.

**Table 105 – Additional test voltages**

<b>Points of application</b>	<b>Test voltage<sup>a</sup></b>
Between the mains supply circuit and <b>accessible parts</b> for metal-encased <b>class II energizers</b>	$2U_0$ but not less than 10 000 V
Between the <b>fence circuit</b> and <b>accessible parts<sup>b</sup></b>	$2U_0$ but not less than 10 000 V
Between the mains supply circuit and the <b>fence circuit</b>	$2U_0$ but not less than 10 000 V
<sup>a</sup> The value $2U_0$ is a peak value equal to twice the maximum peak value of the output voltage measured in 22.111.	
<sup>b</sup> A gap of 50 mm around the output terminal shall be provided in the metal foil in contact with <b>accessible parts</b> .	

**16.101** Immediately after the tests of 16.3, the output characteristics are measured as specified in 22.108.

The values measured shall be within the limits specified in 22.108.

## 17 Overload protection of transformers and associated circuits

This clause of Part 1 is not applicable.

## 18 Endurance

This clause of Part 1 is replaced by the following.

**Mains-operated energizers** and **battery-operated energizers suitable for connection to the mains** shall be so constructed that they are able to endure extreme temperatures that may be encountered in normal use. Moreover, overload **protection devices** shall not operate under these conditions.

Compliance is checked by the following test.

**Mains-operated energizers, type A energizers and type C energizers** when they are connected for mains supply are operated under conditions of **normal operation**. The voltage applied is the **rated voltage**.

**Type D energizers** are operated under conditions of **normal operation**. The voltage applied is as specified in 11.5.

**Type B energizers** connected for battery operation are placed in their normal position and are fitted with a battery having a nominal voltage equal to the **rated voltage for battery supply** of the **energizer**. The battery shall be of the largest capacity for which the **energizer** is designed. The battery shall be fully charged at the beginning of the test and shall be replaced by a fresh one as soon as, during the test, the voltage of the battery decreases to 0,75 times its nominal voltage for a rechargeable battery or to 0,55 times its nominal voltage for a non-rechargeable battery or until the **energizer** ceases to function due to low battery voltage.

For **type A energizers**, a battery of the largest capacity for which the **energizer** is designed is connected and placed in the battery compartment. Before starting the test, the battery is discharged to such an extent that the voltage delivered does not exceed 0,75 times its nominal value.

The other sample, for **type A energizers** and **type C energizers**, is to be connected for battery supply and supplied from a battery of the largest capacity for which the **energizer** is designed. The battery shall be fully charged at the beginning of the test, and shall be replaced by a fresh one as soon as, during the test, the voltage of the battery decreases to 0,75 times its nominal voltage for a rechargeable battery or to 0,55 times its nominal voltage for a non-rechargeable battery.

The **energizer** is operated continuously for 168 h (seven days) at an ambient temperature of  $-15\text{ °C} \pm 2\text{ °C}$  and then for 168 h (seven days) at an ambient temperature of  $50\text{ °C} \pm 2\text{ °C}$ .

The output terminals are loaded with a non-inductive resistor of  $500\ \Omega \pm 2,5\ \Omega$  during the first 84 h of each period of 168 h and the load is removed for the remainder of these periods.

At the end of each of the periods of 168 h, the output characteristics are measured, as specified in 22.108, at the ambient temperature prescribed for the relevant period.

The values measured shall be within the limits specified in 22.108.

During the test, the **energizer** shall show no change impairing its further use, the sealing compound, if any, shall not flow out to such an extent that **live parts** are exposed and the **energizer** shall still meet the requirements of Clause 8.

## 19 Abnormal operation

This clause of Part 1 is applicable except as follows.

### 19.1 Addition:

The **energizer** is mounted as in 11.2, except that the battery, where applicable, is fully charged.

During the tests, fuses that are accessible to the user are short-circuited.

**Energizers** are also subjected to the tests of 19.101, 19.102, 19.103, 19.104 and 19.105.

**Security energizer groups** are also subjected to the tests of 19.106 and 19.107 as if they were an **energizer** supplied in one or more parts.

### 19.12 Addition:

If, for any of the fault conditions, the impulse repetition rate is greater than 1 Hz and the safety of the **energizer** depends upon the operation of a non-self-resetting **protective device** incorporating an internal fuse, the test is carried out three times to ensure that this fuse operates reliably and that internal parts are not damaged at the increased impulse repetition rate.

### 19.13 Addition:

The temperature rises of the windings shall not exceed the values shown in Table 8.

For a **type R security energizer**, during the tests the output characteristics of each **fence circuit** shall be as specified in 22.108 except for the impulse repetition rate and 22.113. If the impulse repetition rate is greater than 1,34 Hz, the discharge energy per second into a load consisting of a non-inductive resistor of  $500\ \Omega$  shall not exceed 1,25 J/s after 3 min.

For all other **energizers**, during the tests the output characteristics of each **fence circuit** shall be as specified in 22.108 except for the impulse repetition rate. If the impulse repetition rate is greater than 1,34 Hz, the discharge energy per second into a load consisting of a non-inductive resistor of 500  $\Omega$  shall not exceed 2,5 J/s after 3 min.

For a **type R security energizer group**, during the tests the impulse synchronisation shall be as specified in 22.114. If the impulse repetition rate is greater than 1,34 Hz, the discharge energy per second into a replacement load consisting of a non-inductive resistor of 500  $\Omega$  shall not exceed 2,5 J/s after 3 min.

For a **type S security energizer group**, during the tests the combined **fence circuit** output characteristics measured in the 500  $\Omega$  resistor  $R_T$  shall be as specified in 22.115 for test configurations 5 and 6 except for the impulse repetition rate. If the impulse repetition rate is greater than 1,34 Hz, the discharge energy per second into the 500  $\Omega$  load  $R_T$  shall not exceed 2,5 J/s after 3 min.

**19.101 Energizers** are subjected to each of the following conditions in turn, while being supplied with the voltage specified in 11.5, including those associated with such other fault conditions that are an actual consequence of the condition chosen:

- the **energizer** is placed in its most unfavourable position even if it is not likely to be installed in this position in normal use;
- parts intended for adjusting the **energizer**, other than those that are adjustable from the outside of the **energizer** without the aid of a **tool**, are adjusted to their most unfavourable position, even if these parts are not intended to be adjusted by the user, unless they are effectively sealed against further adjustment;
- the earthing conductor is removed from the earthing terminal of the **fence circuit** and connected to any other output terminal;
- the output terminals are short-circuited;
- switches, relay-contacts and the like, that form part of the impulse generating circuit, are short-circuited or open-circuited, whichever is the more unfavourable;
- fuses that are accessible without the aid of **tools**, series spark gaps in the **fence circuit**, discharging valves and thermal relays are short-circuited;
- except for **electronic circuits**, any **creepage distance** or **clearance** between **live parts** of different potential that is less than 5 mm for the **fence circuit**, or 2 mm or less for other circuits, is short-circuited, and any unlocked connection is loosened;
- the switching speed of an **electronic component** used as the major impulse-switching device shall be varied in the range 0,1 Hz to twice the **rated frequency**, in approximately a 1:2:5 progression sequence over three decades, by referencing the gate signal of this device to the voltage across it using an external independent control.

NOTE Details of a simple comparator circuit that has been found suitable for controlling the switching speed of the major impulse-switching device are given in Annex AA.

**19.102 Type A energizers, type C energizers and type D energizers** are subjected to each of the following conditions in turn, while being supplied with the voltage specified in 11.5:

- with the **energizer** connected for battery supply, terminals for the connection of the battery having an indication of polarity are connected to the opposite polarity, unless such a connection is unlikely to occur in normal use;
- with the **energizer** connected for mains operation, terminals for the connection of the battery supply are connected to the most unfavourable resistive load, including a short circuit.

**19.103 Type B energizers** connected for mains supply with battery charge operation are subjected to each of the following conditions in turn, while being supplied with the voltage specified in 11.5:

- the terminals for the connection of the battery having an indication of polarity are connected to the opposite polarity, unless such a connection is unlikely to occur in normal use;
- the terminals for the connection of the battery supply are connected to the most unfavourable resistive load, including a short circuit.

**19.104 Type B energizers** connected for battery supply are supplied with the voltage specified in 11.5. The supply terminals having an indication of polarity are connected to the opposite polarity, unless such a connection is unlikely to occur in normal use.

**19.105 Battery operated energizers suitable for connection to the mains having a rated voltage for battery supply** of less than 12 V are operated under **normal operation** when supplied with an input voltage of 13,2 V DC.

During the test, the **energizer** shall be connected to the voltage source via a 1  $\Omega$  series resistor.

This test is only applicable if the supply may be connected without modification of the **energizer**.

**19.106 Type S security energizer groups** are tested for every permitted configuration and connection specified in the instructions. As such, during the tests only a single fault is applied at a time in any one of the parts.

**19.107 Security energizer groups** are subjected to fault testing of the **impulse timing signal source**. All possible **impulse timing signal** outputs are considered for faults occurring within the **impulse timing signal source** such as stopping, intermittent operation, low level, high level, variable rate, high rate. Whenever possible when an external **impulse timing signal source** is used, a fault shall be introduced such that the **impulse timing signal source** is no longer a viable method of synchronization. However if it can be shown that a particular fault condition is unlikely to occur then it should not be considered.

## 20 Stability and mechanical hazards

This clause of Part 1 is not applicable.

## 21 Mechanical strength

This clause of Part 1 is applicable except as follows.

**21.101** The **energizer** shall withstand the effect of being dropped.

*Compliance is checked by the following test.*

The **energizer** is bolted centrally to a board 1 000 mm  $\pm$  5 mm long by 225 mm  $\pm$  5 mm wide and approximately 25 mm thick. The board is supported at each end on a rigid table by baulks of timber of such a size that the **energizer** is held clear of the table surface. One end of the board is lifted through a distance of 200 mm  $\pm$  5 mm and allowed to fall freely. The test is repeated 20 times. This procedure is then repeated with the board placed on each of its other longitudinal edges in turn.

After the test, the **energizer** shall show no damage within the meaning of this standard.

## 22 Construction

This clause of Part 1 is applicable except as follows.

### 22.12 *Addition:*

The requirement is not applicable to the **energizer** output terminal assembly including the terminal knob and washers.

### 22.31 *Addition:*

The requirement applies only to **mains-operated energizers** and **battery-operated energizers suitable for connection to the mains**.

### 22.32 *Addition:*

The requirement applies only to **mains-operated energizers** and **battery-operated energizers suitable for connection to the mains**.

### 22.46 *Addition:*

If programmable **protective electronic circuits** alone are used to ensure compliance with the output characteristics specified in 19.13, the software shall contain measures to control the fault/error conditions specified in Table R.2.

### 22.56 *Replacement:*

For **type D energizers**, a **detachable supply unit** shall be a listed accessory made available by the manufacturer.

*Compliance is checked by inspection.*

**22.101** For **mains-operated energizers** and **battery-operated energizers suitable for connection to the mains**, internal connections shall be so fixed or protected, and **energizers** shall be so designed that, even in the event of the loosening or breaking of wires, a conductive connection cannot be formed between the mains supply and the **fence circuit**, and no other hazardous condition shall arise.

The input winding and the output windings of transformers used to isolate the **fence circuit** from the supply circuit shall be separated by an insulating barrier, and the construction shall be such that there is no possibility of any connection between these windings, either directly or indirectly through other metal parts.

In particular, precautions shall be taken to prevent

- displacement of input or output windings, or the turns thereof;
- undue displacement of parts of windings, or of internal wiring, in the event of a rupture or loosening of connections.

Isolation between the mains and the **fence circuit** may be achieved by the incorporation of a double-wound transformer situated either in the input circuit or in the **fence circuit**. If such transformers are incorporated in both circuits, at least one of these transformers shall provide the required degree of isolation.

*Compliance is checked by inspection and by the tests of the other clauses of this standard.*

NOTE 1 Circuits connected between the input terminals and the primary side of the transformer providing the required degree of isolation are considered to be connected to the mains, and circuits connected between the output terminals and the secondary side of this transformer are considered to belong to the **fence circuit**.

NOTE 2 Examples of constructions that comply with the requirements of this subclause for windings are

- windings on separate spools of adequate insulating material, rigidly fixed with respect to each other and to the core of the transformer;
- windings on a single spool with a partition wall, both of adequate insulating material, provided that the spool and partition wall are pressed or moulded in one piece, or that, in the case of a pushed-on partition wall, there is an intermediate sheath or covering over the joint between the spool and the partition wall;
- concentric windings on cheekless formers, provided that
  - each layer of the winding is interleaved with adequate insulating material projecting beyond the end turns of each layer,
  - one or more separate sheets of insulating material of adequate thickness are provided between the input winding and the output windings, and
  - the windings are impregnated with a hard-baked or other suitable material that fully penetrates the interstices and effectively seals off the end turns.

NOTE 3 It is not to be expected that two independent fixings will become loose at the same time.

**22.102** For **mains-operated energizers** and **battery-operated energizers suitable for connection to the mains**, transformers in the **fence circuit** shall be placed in a separate compartment. This compartment shall not contain any part that is, or can come, in contact with the mains, with the exception of the input winding of the transformer.

*Compliance is checked by inspection and by the tests of the other clauses of this standard.*

**22.103** For metal-encased **class II energizers**, the output terminals shall be placed so that external conductors connected to these terminals are not likely to come into contact with the enclosure.

*Compliance is checked by inspection.*

**22.104** **Energizers** shall be so designed that

- the conductors for the connection of the **fence** and the **earth electrode** can be easily connected;
- it is possible to actuate switches and other controls, if this is necessary in normal use, after the **energizer** has been mounted and connected to the supply, without opening or removing any enclosure that provides protection against harmful ingress of water or unintended electric shock.

*Compliance is checked by inspection.*

**22.105** For **mains-operated energizers** and **battery-operated energizers suitable for connection to the mains**, any assembly gap in **supplementary insulation** shall not be co-incidental with any such gap in **basic insulation**, neither shall any such gap in **reinforced insulation** give straight access to **live parts**.

*Compliance is checked by inspection.*

**22.106** In **type A energizers**, **type B energizers** and **type C energizers**, terminals for the connection of the battery and other metal parts in a battery compartment that become accessible when replacing batteries, even with the aid of a **tool**, shall be insulated from **live parts** by **double insulation** or **reinforced insulation**.

In **type D energizers**, parts in a battery compartment that become accessible when replacing batteries, even with the aid of a **tool**, shall not be **live parts**.

*Compliance is checked by inspection, measurement and by the tests specified for **double insulation** or **reinforced insulation**.*

**22.107 Battery-operated energizers suitable for connection to the mains** shall be provided with means to prevent the user from being subjected to an electric shock due to the **energizer** output voltage, when connecting a battery to the **energizer**.

*Compliance is checked by inspection.*

NOTE Examples of such means are:

- a switch that isolates the terminals for the connection of the battery;
- a control that enables the output voltage to be reduced to zero;
- insulated crocodile clips or similar devices.

**22.108 Energizer** output characteristics shall be such that

- the impulse repetition rate shall not exceed 1 Hz;
- the **impulse duration** of the impulse in the 500  $\Omega$  component of the **standard load** shall not exceed 10 ms;
- for **energy limited energizers**, the energy/impulse in the 500  $\Omega$  component of the **standard load** shall not exceed 5 J;

NOTE The energy/impulse is the energy measured in the impulse over the **impulse duration**.

- for **current limited energizers**, the **output current** in the 500  $\Omega$  component of the **standard load** shall not exceed for
  - an **impulse duration** of greater than 0,1 ms, the value specified by the characteristic limit line detailed in Figure 103;
  - an **impulse duration** of less than or equal to 0,1 ms, 15 700 mA.

*Compliance is checked by measurement when the **energizer** is supplied with the voltage in 11.5, the **energizer** being operated under conditions of **normal operation** but with the **standard load** connected to its output terminals. For **energizers** with more than one set of output terminals, the **standard load** is connected to each set of output terminals in turn. When measuring the impulse repetition rate, the **standard load** is not connected.*

*The measurements are made using a measuring arrangement with an input impedance consisting of a non-inductive resistance of not less than 1 M $\Omega$  in parallel with a capacitance of not more than 100 pF.*

**22.109** If the **energizer** is provided with more than one set of output terminals, the output characteristics shall be within the limits specified in 22.108 for any possible configuration of the output terminals connected to the **standard load**.

The impulses for the individual sets of output terminals shall be synchronized and

- the **impulse duration** shall not exceed the value specified in 22.108;
- the impulse repetition rate shall not exceed the value specified in 22.108

for any possible combination of individual impulses.

*Compliance is checked by the measurements specified in 22.108.*

**22.110** For **type A energizers** and **type B energizers** that have terminals for the connection of the battery, the no-load DC output voltage shall not exceed 42,4 V.

Compliance is checked by measuring the no-load DC output voltage appearing at the terminals for the connection of the battery when the **energizer** is connected for mains supply and is supplied at **rated voltage**.

**22.111** The peak value of the output voltage,  $U_0$ , shall be measured and recorded to enable the tests and measurements of 14.102, 14.103, 14.104 and 16.3 to be carried out.

Compliance is checked by the following tests:

When the **energizer** is a **security energizer** marked as being permitted for use in a **security energizer group**, the peak value of the output voltage,  $U_0$ , should be the highest value of voltage measured when it is connected in a **security energizer group** and tested in any permitted configuration and connection of **security energizers** that may be used in the **security energizer group** given in the instructions. The **security energizer group** is supplied with the voltage in 11.5 under conditions of **normal operation**, but with a load connected to the output terminals of the **security energizer** or **security energizer group**, consisting of a capacitor having a capacitance that can be varied between 0 nF and 200 nF in steps of approximately 10 nF.

These **security energizer group** tests are not applicable to a **type R security energizer group** where all the **type R energizers** in the group are exactly the same model.

For all other **energizers**, the peak value of the output voltage,  $U_0$ , is measured, using an arrangement described in 22.108 with the **energizer** supplied with the voltage in 11.5 under conditions of **normal operation**, but with a load connected to the output terminals consisting of a capacitor having a capacitance that can be varied between 0 nF and 200 nF in steps of approximately 10 nF.

**22.112** The **clearance** between parts of opposite polarity for connecting the battery in **battery operated energizers suitable for connections to the mains** shall not be less than 2 mm, when the **energizer** is fitted with conductors as in normal use.

Compliance is checked by measurement.

**22.113** For a **type R security energizer**, the energy per impulse delivered by each **fence circuit** into the **standard load** shall not exceed 2,5 J.

Compliance is checked by measuring the energy/impulse over the **impulse duration** with the **energizer** is supplied with the voltage in 11.5, the **energizer** being operated under conditions of **normal operation** but with the **standard load** connected to each **fence circuit**.

When measuring the energy per impulse into the **standard load**, the variable resistor shall be adjusted to maximize the energy into the **standard load** and not the energy in the 500  $\Omega$  component of the **standard load**.

The measurements are made using a measuring arrangement with an input impedance consisting of a non-inductive resistance of not less than 1 M $\Omega$  in parallel with a capacitance of not more than 100 pF.

**22.114** **Type R security energizer group** output characteristics measured in the 500  $\Omega$  component of the **standard load** shall be such that

- the impulse repetition rate shall not exceed 1 Hz;
- the **impulse duration** of the impulse shall not exceed 10 ms.

Compliance is checked by measurement when the **type R security energizer group** is supplied with the voltage in 11.5, being operated under conditions of **normal operation** but with the **standard load** connected to the output terminals as shown in Figure 104, Test

configuration A and the test repeated with the **standard load** connected to the output terminals as shown in Figure 104, Test configuration B.

The measurements are made using a measuring arrangement with an input impedance consisting of a non-inductive resistance of not less than 1 M $\Omega$  in parallel with a capacitance of not more than 100 pF.

**22.115 Type S security energizer group** output characteristics measured in the 500  $\Omega$  resistor  $R_T$  shall be such that

- the impulse repetition rate shall not exceed 1 Hz;
- the **impulse duration** of the impulse shall not exceed 10 ms;
- for **energy limited energizers**, the energy/impulse shall not exceed 5 J;

NOTE The energy/impulse is the energy measured in the impulse over the **impulse duration**.

- for **current limited energizers**, the **output current** shall not exceed for
  - an **impulse duration** of greater than 0,1 ms, the value specified by the characteristic limit line detailed in Figure 103;
  - an **impulse duration** less than or equal to 0,1 ms, 15 700 mA.

Compliance is checked with the **type S security energizer group** supplied with the voltage specified in 11.5, and operated with the six test configurations shown in Figure 105, in turn. For each configuration, the test loads are varied as follows.

- a) With resistor  $R_T$  connected, for test configurations 1 to 6, vary resistor  $R_A$  and resistor  $R_B$  to maximise the group output characteristics measured in resistor  $R_T$ ;
- b) With resistor  $R_T$  disconnected, for test configuration 1, vary resistor  $R_B$  to maximize the output characteristics measured in resistor  $R_B$  then reconnect resistor  $R_T$  and measure the group output characteristics in resistor  $R_T$ ;
- c) With resistor  $R_T$  disconnected, for test configuration 2, vary resistor  $R_A$  to maximize the output characteristics measured in resistor  $R_A$  then reconnect resistor  $R_T$  and measure the group output characteristics in resistor  $R_T$ ;
- d) With resistor  $R_T$  disconnected, for test configuration 6, vary resistor  $R_A$  and resistor  $R_B$  to maximize the output characteristics measured in resistor  $R_A$  and resistor  $R_B$  then reconnect resistor  $R_T$  and measure the group output characteristics in resistor  $R_T$ ;
- e) With resistor  $R_T$  disconnected, for test configurations 3, 4 and 5, vary resistor  $R_A$  and resistor  $R_B$  to maximize the output characteristics measured in resistor  $R_A$  and resistor  $R_B$  then reconnect resistor  $R_T$  and measure the group output characteristics in resistor  $R_T$ .

The measurements are made using a measuring arrangement with an input impedance consisting of a non-inductive resistance of not less than 1 M $\Omega$  in parallel with a capacitance of not more than 100 pF.

For each test, the **type S security energizer group** output characteristics measured in the 500  $\Omega$  resistor  $R_T$  shall not be exceeded.

## 23 Internal wiring

This clause of Part 1 is applicable except as follows.

### 23.7 Replacement:

For **mains-operated energizers and battery-operated energizers suitable for connection to the mains**, conductors identified by the colour combination green/yellow shall not be used.

*Compliance is checked by inspection.*

## 24 Components

This clause of Part 1 is applicable.

## 25 Supply connection and external flexible cords

This clause of Part 1 is applicable except as follows.

### 25.1 Addition:

For **Type D energizers** that are provided with a non-detachable flexible cord, the connecting means shall not be suitable for connection to the mains.

An appliance inlet, on a **type D energizer**, shall have at least the same degree of protection against moisture as required for the **energizer** and shall not be compatible with appliance couplers complying with the standard sheets of IEC 60320-3.

*Compliance is checked by inspection.*

### 25.7 Replacement:

**Supply cords** shall not be lighter than

- ordinary polyvinyl chloride sheathed cord (code designation 60227 IEC 53);
- ordinary polychloroprene sheathed cord (code designation 60245 IEC 57).

The ordinary polychloroprene sheathed cord shall be used where, for climatic reasons, the ordinary polyvinyl chloride sheathed cord is not suitable.

*Compliance is checked by inspection.*

### 25.8 Addition:

The conductors in flexible leads or flexible cords used to connect the battery in **type D energizers** shall have a nominal cross-sectional area of not less than 0,75 mm<sup>2</sup>.

### 25.13 Addition:

This requirement is not applicable to the flexible leads or flexible cord connecting external batteries or a **battery box** with an **energizer**.

### 25.23 Addition:

In **battery-operated energizers suitable for connection to the mains**, if the battery is placed in a separate box, the flexible lead or flexible cord connecting the box with the **energizer** is considered to be an **interconnection cord**.

## 26 Terminals for external conductors

This clause of Part 1 is applicable except as follows.

### 26.1 Addition:

The second sentence of the requirement does not apply to the **energizer** output terminals.

**26.5** *Addition:*

Terminal devices in an **energizer** for the connection of the flexible leads or flexible cord with **type X attachment** connecting an external battery or **battery box** shall be so located or shielded that there is no risk of accidental connection between supply terminals.

**26.9** *Addition:*

The requirement does not apply to the **energizer** output terminals.

**26.101** Output terminals shall be so designed or located that it is not possible to connect the **fence** or the **earth electrode** to the **energizer** by means of a plug that is designed for connection to a socket-outlet for mains supply.

*Compliance is checked by inspection and by manual test.*

**26.102** Output terminals shall be fixed so that they will not work loose when external conductors are connected or disconnected.

*Compliance is checked by inspection and by manual test.*

**26.103** Devices for clamping the conductors connecting the **fence** or the **earth electrode** to the **energizer** shall not serve to fix any other component.

*Compliance is checked by inspection.*

## **27 Provision for earthing**

This clause of Part 1 is applicable except as follows.

**27.1** *Addition:*

NOTE 101 In **class II energizers**, provision can be made for connecting at least one of the output terminals to the **earth electrode**.

## **28 Screws and connections**

This clause of Part 1 is applicable.

## **29 Clearances, creepage distances and solid insulation**

This clause of Part 1 is applicable.

## **30 Resistance to heat and fire**

This clause of Part 1 is applicable except as follows.

**30.2.1** *Modification:*

The glow-wire test is made at a temperature of 650 °C.

**30.2.2** Not applicable.

### **31 Resistance to rusting**

This clause of Part 1 is replaced by the following.

The enclosure of metal-encased **class II energizers** shall be adequately protected against corrosion.

*Compliance is checked by the salt mist test of IEC 60068-2-52. Test method 2 is applicable.*

*Before the test, coatings are scratched by means of a hardened steel pin, the end of which has the form of a cone with an angle of 40°. Its tip is rounded with a radius of 0,25 mm ± 0,02 mm. The pin is loaded so that the force exerted along its axis is 10 N ± 0,5 N. The scratches are made by drawing the pin along the surface of the coating at a speed of approximately 20 mm/s. Five scratches are made at least 5 mm apart and at least 5 mm from the edge.*

*After the test, the appliance shall not have deteriorated to such an extent that compliance with this standard is impaired. The coating shall not have broken and shall not have loosened from the metal surface.*

### **32 Radiation, toxicity and similar hazards**

This clause of Part 1 is applicable.

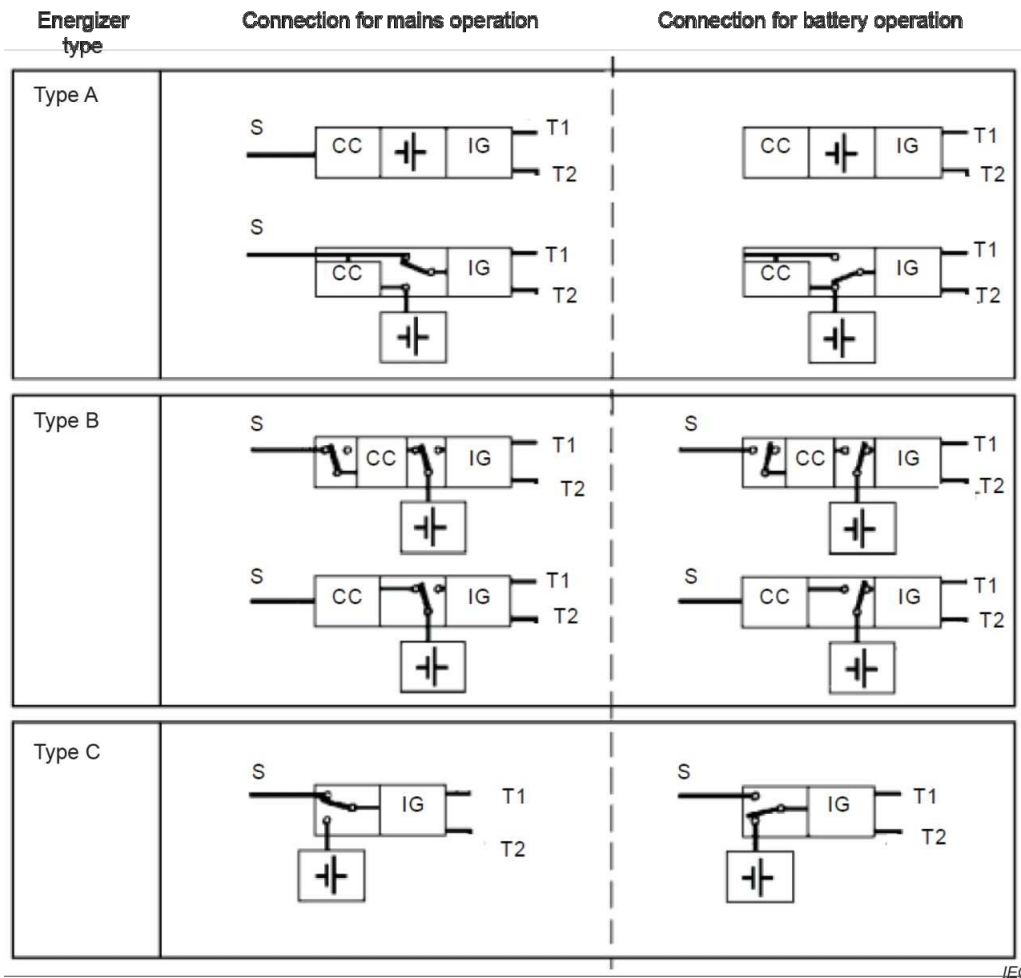

IEC

**Key**

- S supply mains  
 CC battery charging circuit  
 IG impulse generating circuit  
 battery  
 T1, T2 output terminals

**Figure 101 – Schematic examples of type A energizers, type B energizers and type C energizers**

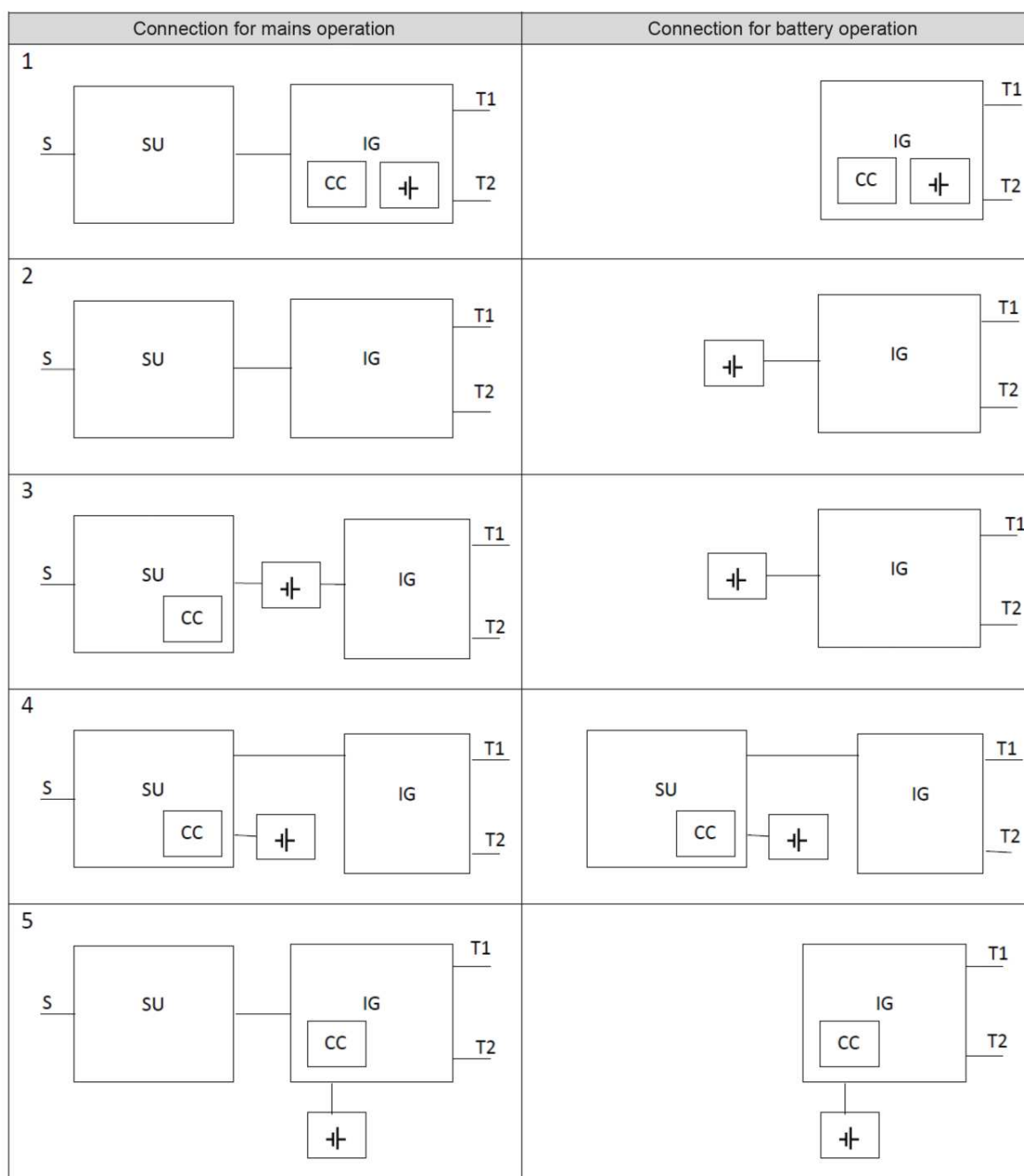

IEC

**Key**

- S supply mains
- SU detachable supply unit
- CC battery charging circuit
- IG impulse generating circuit
-  battery
- T1, T2 output terminals

**Figure 102 – Schematic examples of the different types of type D energizers**

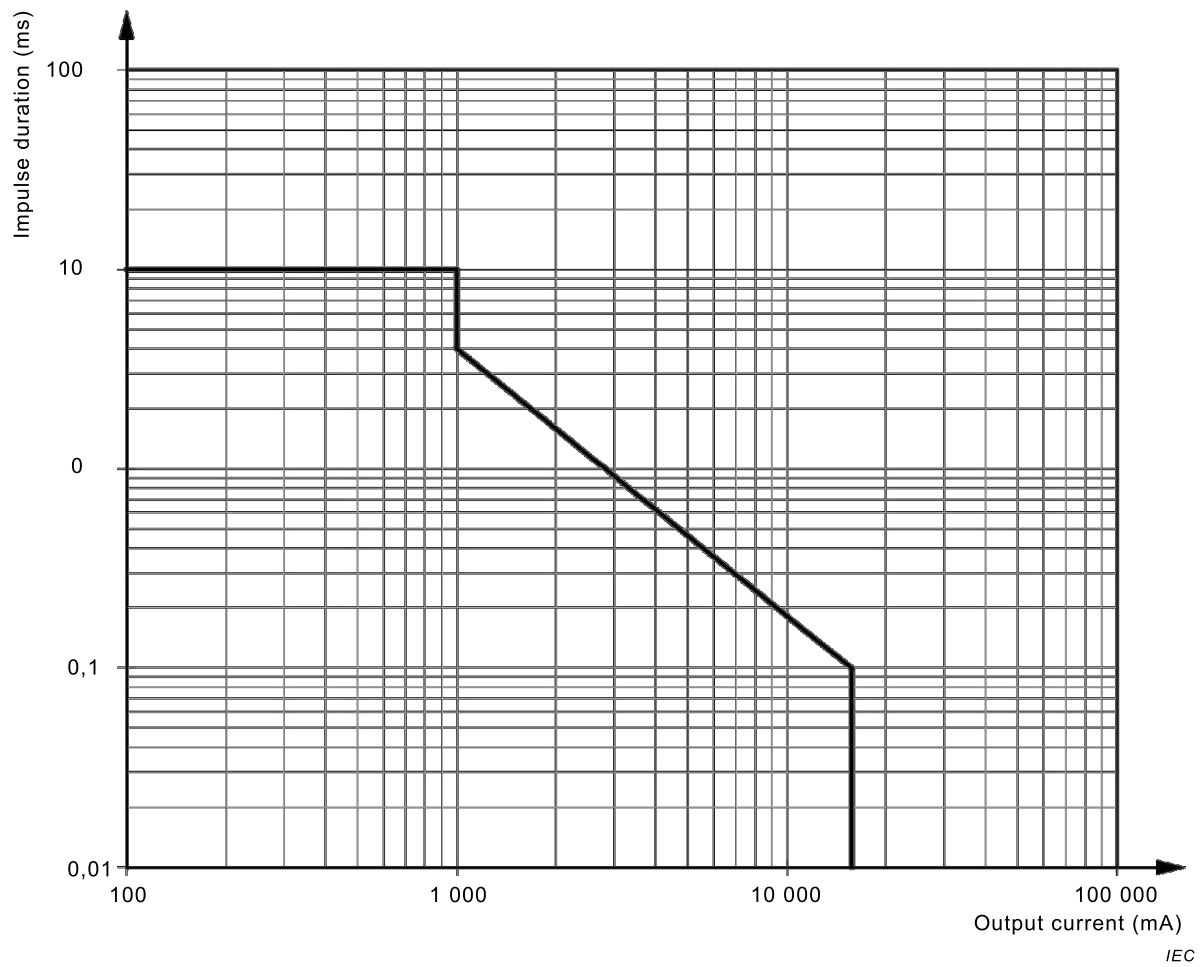

NOTE The equation of the line relating **impulse duration** (ms) to **output current** (mA) for  $1\,000\text{ mA} < \text{output current} < 15\,700\text{ mA}$ , is given by  $\text{impulse duration} = 41,885 \times 10^3 \times (\text{output current})^{-1.34}$ .

**Figure 103 – Current limited energizer characteristic limit line**

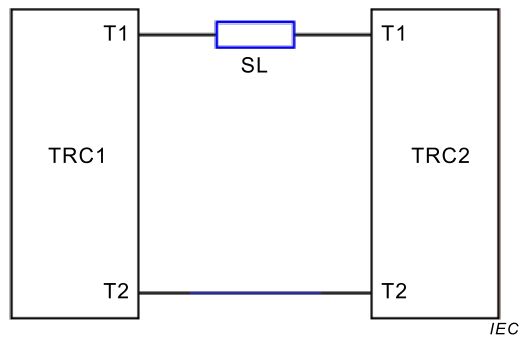

Test configuration A

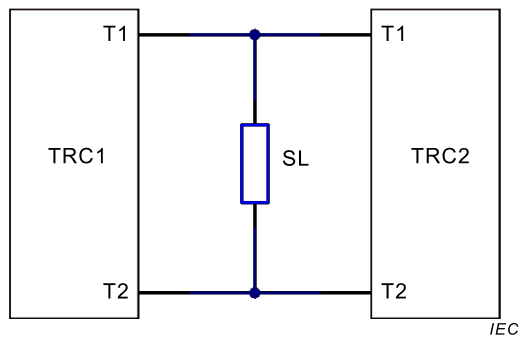

Test configuration B

**Key**

TRC1 type R fence circuit 1

TRC2 type R fence circuit 2

SL **standard load**

T1, T2 **type R security energizer group output terminals**

**Figure 104 – Type R security energizer group test configurations**

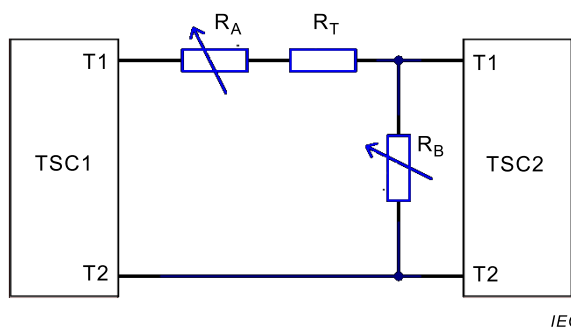

IEC

Test configuration 1

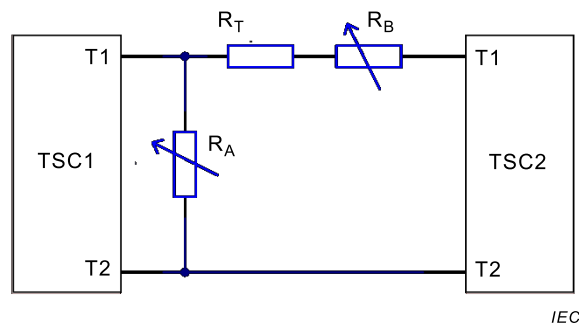

IEC

Test configuration 2

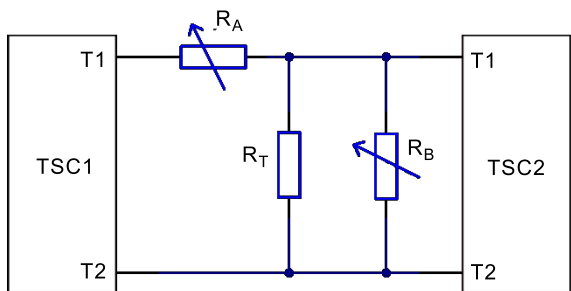

IEC

Test configuration 3

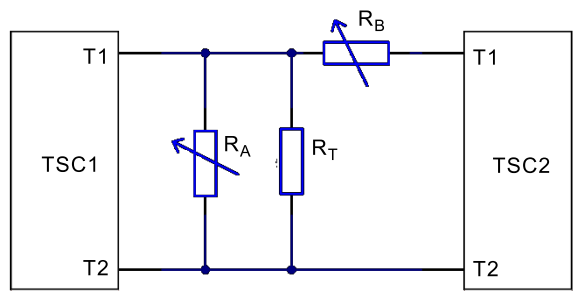

IEC

Test configuration 4

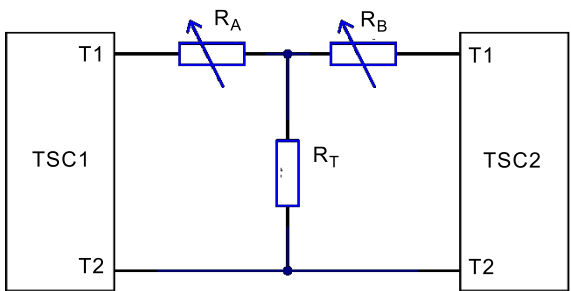

IEC

Test configuration 5

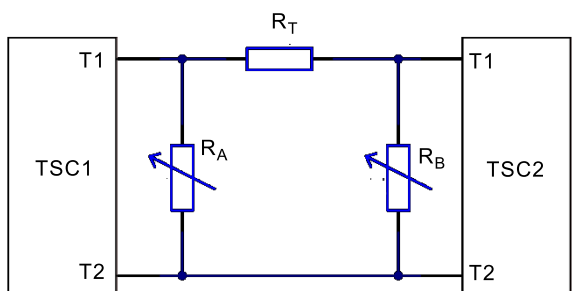

IEC

Test configuration 6

**Key**

TSC1 type S fence circuit 1

TSC2 type S fence circuit 2

RA variable resistor

RB variable resistor

RT 500 Ω resistor

T1, T2 type S security energizer group output terminals

**Figure 105 – Type S security energizer group test configurations**

## Annexes

The annexes of Part 1 are applicable except as follows.

### Annex A (informative)

#### Routine tests

This annex of Part 1 is applicable except as follows.

#### A.2 Electric strength test

*Addition:*

*For mains-operated energizers and battery-operated energizers suitable for connection to the mains, an electric strength test is carried out between the supply circuit and the fence circuit, the test voltage being 10 000 V AC, 50 Hz or 60 Hz, or 15 000 V DC for 1 s.*

#### A.3 Functional test

*Addition:*

*The energizer output characteristic shall be checked by operating the energizer at rated voltage with a 500  $\Omega$  load connected across the output terminals.*

*The energizer output characteristic shall be such that*

- the impulse repetition rate shall not exceed 1 Hz;*
- the impulse duration of the impulse shall not exceed 10 ms;*
- for energy limited energizers, the energy/impulse shall not exceed 5 J;*
- for current limited energizers, the output current shall not exceed*
  - the value specified by the characteristic limit line detailed in Figure 103;*
  - for an impulse duration of less than 0,1 ms, 15 700 mA.*

## Annex B (normative)

### Appliances powered by rechargeable batteries that are recharged in the appliance

This annex of Part 1 is applicable along with the following additions and modifications.

NOTE B.101 Rechargeable batteries that are recharged while connected to the appliance are considered to be recharged in the appliance.

#### 7 Marking and instructions

##### 7.1 Addition:

**Energizers** supplied by other sources of energy and not suitable for connection to the supply mains shall be marked with the symbol for “connection to mains operated equipment prohibited” or with the substance of the following warning:

WARNING: Do not connect to mains-operated equipment such as battery chargers.

The rules for a prohibition sign in ISO 3864-1, except for colours, apply to the symbol for connection to mains-operated equipment prohibited.

##### Modification:

The text referring to the **detachable supply unit** is not applicable.

##### 7.6 Addition:



connection to mains-operated equipment prohibited

##### 7.12 Addition:

If the symbol for “connection to mains-operated equipment prohibited” is used, its meaning shall be explained.

##### Modification:

The warning referring to the **detachable supply unit** is replaced by the substance of the following.

WARNING: Use only a detachable supply unit that is listed as an accessory made available by the manufacturer.

Add the following subclause:

##### 7.14 Addition:

If the symbol for “connection to mains-operated equipment prohibited” is marked on the appliance, the outer diameter of the circle shall be at least 15 mm.

**7.15** Not applicable.

### **30 Resistance to heat and fire**

**30.2** This subclause of Part 1 is not applicable.

## Annex S (normative)

### Battery-operated appliances powered by batteries that are non-rechargeable or not recharged in the appliance

This annex of Part 1 is applicable along with the following additions and modifications.

#### 7 Marking and instructions

##### 7.1 Addition:

**Battery-operated energizers** shall be marked with the symbol for “connection to mains operated equipment prohibited” or with the substance of the following warning:

WARNING: Do not connect to mains-operated equipment such as battery chargers.

The rules for a prohibition sign in ISO 3864-1, except for colours, apply to the symbol for connection to mains-operated equipment prohibited.

##### 7.6 Addition:

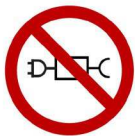

connection to mains-operated equipment prohibited

##### 7.12 Addition:

If the symbol for “connection to mains-operated equipment prohibited” is used, its meaning shall be explained.

*Add the following subclause.*

##### 7.14 Addition:

If the symbol for “connection to mains-operated equipment prohibited” is marked on the appliance, the outer diameter of the circle shall be at least 15 mm.

*Add the following clause.*

#### 14 Transient voltages

##### 14.1 Addition:

**Battery-operated energizers** having a **rated voltage** exceeding 42,4 V are installed as in normal use and are then subjected to the test of 14.S.101.

**14.S.101** Five positive and five negative impulses, each having a **prospective peak voltage** of  $2U_0$  but not less than 25 kV, are applied between the output terminals, the interval between the impulses being at least 10 s. The input terminals are open-circuited.

*Add the following clause.*

## 16 Leakage current and electric strength

### 16.1 Addition:

**Battery-operated energizers** are subjected to the tests of 16.S.101.

**16.S.101** For **battery-operated energizers**, the supply terminals are connected for 10 min to a voltage between 1,1 and 1,5 times **rated voltage for battery supply**, that is so chosen that the output voltage, without a load connected, has the maximum value, protective spark gaps, if any, being disconnected.

No breakdown shall occur during the test.

Immediately after the tests, the output characteristics are measured as specified in 22.108.

The values measured shall be within the limits specified in 22.108.

Add the following clause.

## 18 Endurance

### Addition:

**Battery-operated energizers** shall be so constructed that they are able to endure extreme temperatures that may be encountered in normal use. Moreover, overload **protection devices** shall not operate under these conditions.

Compliance is checked by the following test.

**Battery-operated energizers** are placed in their normal position and are fitted with a battery having a nominal voltage equal to the **rated voltage** of the energizer. The battery shall be of the largest capacity for which the energizer is designed. The battery shall be fully charged at the beginning of the test and shall be replaced by a fresh one as soon as, during the test, the voltage of the battery decreases to 0,75 times its nominal voltage for a rechargeable battery or to 0,55 times its nominal voltage for a non-rechargeable battery or until the **energizer** ceases to function due to low battery voltage.

The **energizer** is operated continuously for 168 h (seven days) at an ambient temperature of  $-15\text{ °C} \pm 2\text{ °C}$  and then for 168 h (seven days) at an ambient temperature of  $50\text{ °C} \pm 2\text{ °C}$ .

The output terminals are loaded with a non-inductive resistor of  $500\ \Omega \pm 2,5\ \Omega$  during the first 84 h of each period of 168 h and the load is removed for the remainder of these periods.

At the end of each of the periods of 168 h, the output characteristics are measured, as specified in 22.108, at the ambient temperature prescribed for the relevant period.

The values measured shall be within the limits specified in 22.108.

During the test, the **energizer** shall show no change impairing its further use, the sealing compound, if any, shall not flow out to such an extent that live parts are exposed and the **energizer** shall still meet the requirements of Clause 8.

## 19 Abnormal operation

**19.S.103 Battery operated energizers** having a rated voltage of less than 12 V are operated under **normal operation** when supplied with an input voltage of 13,2 V DC.

*During the test, the **energizer** shall be connected to the voltage source via a 1  $\Omega$  series resistor.*

*This test is only applicable if the supply may be connected without modification of the **energizer**.*

*Add the following clause.*

## 22 Construction

**22.S.101** For **battery-operated energizers**, parts in a battery compartment that become accessible when replacing batteries, even with the aid of a **tool**, shall not be **live parts**.

*Compliance is checked by inspection, measurement and by the tests specified for **double insulation** or **reinforced insulation**.*

**22.S.102 Battery-operated energizers** shall be provided with means to prevent the user from being subjected to an electric shock due to the **energizer** output voltage, when connecting a battery to the **energizer**.

*Compliance is checked by inspection.*

NOTE Examples of such means are:

- a switch that isolates the terminals for the connection of the battery;
- a control that enables the output voltage to be reduced to zero;
- insulated crocodile clips or similar devices.

**22.S.103** The **clearance** between parts of opposite polarity for connecting the battery in **battery operated energizers** shall not be less than 2 mm, when the **energizer** is fitted with conductors as in normal use.

*Compliance is checked by measurement.*

## 25 Supply connection and external flexible cords

*Add the following new subclauses.*

### 25.7 Addition:

This requirement is not applicable to the flexible leads or flexible cord connecting external batteries or a **battery box** to a **battery-operated energizer**.

### 25.23 Addition:

In **battery-operated energizers**, if the battery is placed in a box, the flexible lead or flexible cord connecting the box with the **energizer** is considered to be an **interconnection cord**.

**25.S.101** *Addition:*

The conductors in flexible leads or flexible cords used to connect the battery in **battery-operated energizers** shall have a nominal cross-sectional area of not less than 0,75 mm<sup>2</sup>.

## Annex AA (informative)

### Circuit for the independent control of the switching speed of the major impulse-switching device

A suitable circuit for external independent control of the switching speed of semiconductor devices used as the major impulse-switching device in the **energizer**, in accordance with the eighth dashed item of 19.101, is shown in Figure AA.1.

The circuit is used to reference the gate signal of the major impulse-switching device to the voltage across this device so that it can be triggered at the same point in the charging cycle.

The reference voltage should be of such a value that the comparator is adjustable over the whole range of the **energizer** charging voltage, thereby allowing the switching speed to be set at any desired frequency.

The input impedance of the comparator circuit should be such that it does not influence the results of the test.

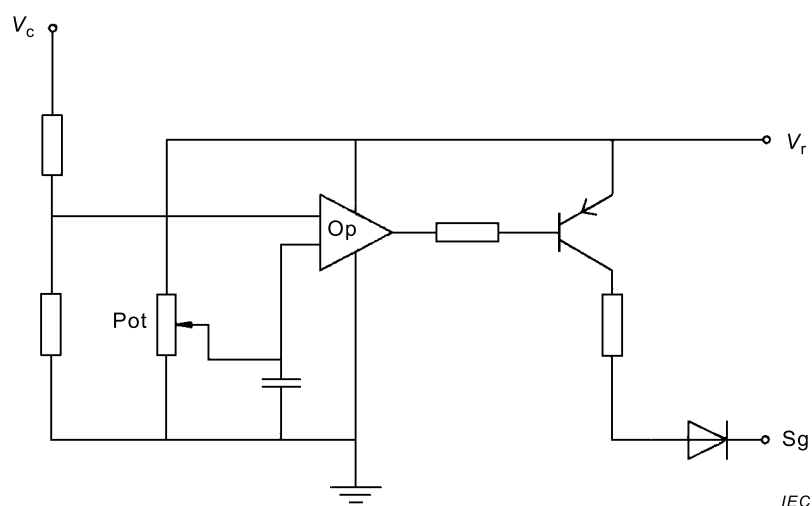

#### Key

- $V_c$  charging voltage
- $V_r$  reference voltage
- Sg gate signal
- Pot switching speed adjustor
- Op comparator

**Figure AA.1 – Circuit for the independent control of the switching speed  
of the major impulse-switching device**

## Annex BB (normative)

### Instructions for installation and connection of electric fences

#### BB.1 Instructions for electric animal fences

For the purpose of these instructions, the term **connecting leads** means electric conductor, used to connect the **energizer** to the **electric fence** or the **earth electrode**.

**Electric animal fences** and their ancillary equipment shall be installed, operated and maintained in a manner that minimizes danger to persons, animals or their surroundings.

**Electric animal fence** constructions that are likely to lead to the entanglement of animals or persons shall be avoided.

WARNING: Avoid contacting electric fence wires especially with the head, neck or torso. Do not climb over, through or under a multi-wire electric fence. Use a gate or a specially designed crossing point.

An **electric animal fence** shall not be supplied from two separate **energizers** or from independent **fence circuits** of the same **energizer**.

For any two separate **electric animal fences**, each supplied from a separate **energizer** independently timed, the distance between the wires of the two **electric animal fences** shall be at least 2,5 m. If this gap is to be closed, this shall be effected by means of electrically non-conductive material or an isolated metal barrier.

Barbed wire or razor wire shall not be electrified by an **energizer**.

A non-electrified **fence** incorporating barbed wire or razor wire may be used to support one or more off-set electrified wires of an **electric animal fence**. The supporting devices for the electrified wires shall be constructed so as to ensure that these wires are positioned at a minimum distance of 150 mm from the vertical plane of the non-electrified wires. The barbed wire and razor wire shall be earthed at regular intervals.

Follow the energizer manufacturer's recommendations regarding earthing.

A distance of at least 10 m shall be maintained between the **energizer earth electrode** and any other earthing system connected parts such as the power supply system protective earth or the telecommunication system earth.

**Connecting leads** that are run inside buildings shall be effectively insulated from the earthed structural parts of the building. This may be achieved by using insulated high voltage cable.

**Connecting leads** that are run underground shall be run in conduit of insulating material or else insulated high voltage cable shall be used. Care shall be taken to avoid damage to the **connecting leads** due to the effects of animal hooves or tractor wheels sinking into the ground.

**Connecting leads** shall not be installed in the same conduit as the mains supply wiring, communication cables or data cables.

**Connecting leads** and **electric animal fence** wires shall not cross above overhead power or communication lines.

Crossings with overhead power lines shall be avoided wherever possible. If such a crossing cannot be avoided it shall be made underneath the power line and as nearly as possible at right angles to it.

If **connecting leads** and **electric animal fence** wires are installed near an overhead power line, the clearances shall not be less than those shown in Table BB.1.

**Table BB.1 – Minimum clearances from power lines for electric animal fences**

Power line voltage V	Clearance m
≤ 1 000	3
> 1 000 and ≤ 33 000	4
> 33 000	8

If **connecting leads** and **electric animal fence** wires are installed near an overhead power line, their height above the ground shall not exceed 3 m.

This height applies to either side of the orthogonal projection of the outermost conductors of the power line on the ground surface, for a distance of

- 2 m for power lines operating at a nominal voltage not exceeding 1 000 V;
- 15 m for power lines operating at a nominal voltage exceeding 1 000 V.

**Electric animal fences** intended for deterring birds, household pet containment or training animals such as cows need only be supplied from low output **energizers** to obtain satisfactory and safe performance.

In **electric animal fences** intended for deterring birds from roosting on buildings, no **electric fence** wire shall be connected to the **energizer earth electrode**. A warning sign shall be fitted to every point where persons may gain ready access to the conductors.

Where an **electric animal fence** crosses a public pathway, a non-electrified gate shall be incorporated in the **electric animal fence** at that point or a crossing by means of stiles shall be provided. At any such crossing, the adjacent electrified wires shall carry warning signs.

Any part of an **electric animal fence** that is installed along a public road or pathway shall be identified at frequent intervals by warning signs securely fastened to the **fence** posts or firmly clamped to the **fence** wires.

The size of the warning sign shall be at least 100 mm × 200 mm.

The background colour of both sides of the warning sign shall be yellow. The inscription on the sign shall be black and shall be either

- the symbol of Figure BB.1, or
- the substance of “CAUTION: **Electric fence**”.

The inscription shall be indelible, inscribed on both sides of the warning sign and have a height of at least 25 mm.

Ensure that all mains-operated, ancillary equipment connected to the **electric animal fence circuit** provides a degree of isolation between the **fence circuit** and the supply mains equivalent to that provided by the **energizer**.

NOTE Ancillary equipment that complies with the requirements relating to isolation between the **fence circuit** and the supply mains in Clauses 14, 16 and 29 of the standard for the **electric fence energizer** is considered to provide an adequate level of isolation.

Protection from the weather shall be provided for the ancillary equipment unless this equipment is certified by the manufacturer as being suitable for use outdoors, and is of a type with a minimum degree of protection IPX4.

## BB.2 Instructions for electric security fences not supplied from a security energizer group

For the purpose of these instructions, the term:

- **connecting leads** means electric conductor, used to connect the **energizer** to the **electric fence** or the **earth electrode**;
- **physical barrier** means a barrier not less than 1,5 m high intended to prevent inadvertent contact with the **pulsed conductors** of the **electric fence**;
- **secure area** means an area where a person is not separated from **pulsed conductors** below 1,5 m by a **physical barrier**;
- **public access area** means any area where persons are protected from inadvertent contact with **pulsed conductors** by a **physical barrier**;
- **pulsed conductors** means conductors that are subjected to high voltage pulses by the **energizer**.

**Electric security fences** and their ancillary equipment shall be installed, operated and maintained in a manner that minimizes danger to persons, and reduces the risk of persons receiving an electric shock unless they attempt to penetrate the **physical barrier**, or are in the **secure area** without authority.

**Electric security fence** constructions that are likely to lead to the entanglement of persons shall be avoided.

Gates in **electric security fences** shall be capable of being opened without the person receiving an electric shock.

An **electric security fence** shall not be supplied from two separate **energizers** or from independent **fence circuits** of the same **energizer**.

For any two separate **electric security fences**, each supplied from a separate **energizer**, the distance between the wires of the two separate **electric security fences** shall be at least 2,5 m. If this gap is to be closed, this shall be effected by means of a physical barrier of high voltage insulating material or earthed conducting material such that the two separate **electric security fences** cannot be contacted at the same time.

A spacing of 2,5 m shall be maintained between uninsulated **connecting leads** supplied from separate **energizers**. This spacing may be less where

- the connecting leads are covered by insulating sleeving rated to at least 10 kV at mains frequency; or
- the connecting leads consist of insulated cables rated to at least 10 kV at mains frequency.

Barbed wire or razor wire shall not be electrified by an **energizer**.

For earthing recommendations, follow the relevant national standard for **electric security fence** earthing. If this does not exist then follow the **energizer** manufacturer's instructions and recommendations.

The distance between any **electric security fence earth electrode** and other earth systems shall be not less than 2 m, except when associated with a graded earth mat.

Where possible, the distance between any electric **security fence earth electrode** and other earth systems should preferably be at least 10 m.

Exposed conductive parts of the **physical barrier** shall be effectively earthed.

Where an **electric security fence** passes below bare power line conductors, the highest metallic element shall be effectively earthed for a distance of not less than 5 m on either side of the crossing point.

**Connecting leads** that are run inside buildings shall be effectively insulated from the earthed structural parts of the building. This may be achieved by using insulated high voltage cable.

**Connecting leads** that are run underground shall be run in conduit of insulating material or else insulated high voltage cable shall be used. Care shall be taken to avoid damage to the **connecting leads** due to the effects of vehicle wheels sinking into the ground.

**Connecting leads** shall not be installed in the same conduit as the mains supply wiring, communication cables or data cables.

**Connecting leads** and **electric security fence** wires shall not cross above overhead power or communication lines.

Crossings with overhead power lines shall be avoided wherever possible. If such a crossing cannot be avoided, it shall be made underneath the power line and as nearly as possible at right angles to it.

If **connecting leads** and **electric security fence** wires are installed near an overhead power line, the clearances shall not be less than those shown in Table BB.2.

**Table BB.2 – Minimum clearances from power lines for electric security fences not supplied from a security energizer group**

Power line voltage V	Clearance m
≤ 1 000	3
> 1 000 and ≤ 33 000	4
> 33 000	8

If **connecting leads** and **electric security fence** wires are installed near an overhead power line, their height above the ground shall not exceed 3 m.

This height applies to either side of the orthogonal projection of the outermost conductors of the power line on the ground surface, for a distance of

- 2 m for power lines operating at a nominal voltage not exceeding 1 000 V;
- 15 m for power lines operating at a nominal voltage exceeding 1 000 V.

**Electric security fences** shall be identified by prominently placed warning signs.

The warning signs shall be legible from the **secure area** and the **public access area**.

Each side of the **electric security fence** shall have at least one warning sign.

Warning signs shall be placed

- at each gate;
- at each access point;
- at intervals not exceeding 10 m;
- adjacent to each sign relating to chemical hazards for the information of the emergency services.

Any part of an **electric security fence** that is installed along a public road or pathway shall be identified at frequent intervals by warning signs securely fastened to the **fence** posts or firmly clamped to the **fence** wires.

The size of the warning sign shall be at least 100 mm × 200 mm.

The background colour of both sides of the warning sign shall be yellow. The inscription on the sign shall be black and shall be either

- the symbol of Figure BB.1, or
- the substance of “CAUTION: **Electric fence**”.

The inscription shall be indelible, inscribed on both sides of the warning sign and have a height of at least 25 mm.

Ensure that all mains operated, ancillary equipment connected to the **electric security fence circuit** provides a degree of isolation between the **fence circuit** and the supply mains equivalent to that provided by the **energizer**.

NOTE 2 Ancillary equipment that complies with the requirements relating to isolation between the **fence circuit** and the supply mains in Clauses 14, 16 and 29 of the standard for the **electric fence energizer** is considered to provide an adequate level of isolation.

Mains supply wiring shall not be installed in the same conduit as signalling leads associated with the **electric security fence** installation.

Protection from the weather shall be provided for the ancillary equipment unless this equipment is certified by the manufacturer as being suitable for use outdoors, and is of a type with a minimum degree of protection IPX4.

### **BB.3 Instructions for electric security fences supplied from a security energizer group**

For the purpose of these instructions the term:

- **connecting leads** means electric conductor, used to connect the **energizer** to the **electric fence** or the **earth electrode**;
- **physical barrier** means a barrier not less than 1,5 m high intended to prevent inadvertent contact with the **pulsed conductors** of the **electric fence**;
- **secure area** means an area where a person is not separated from **pulsed conductors** below 1,5 m by a **physical barrier**;
- **public access area** means any area where persons are protected from inadvertent contact with **pulsed conductors** by a **physical barrier**;
- **pulsed conductors** means conductors that are subjected to high voltage pulses by the **energizer**.

**Electric security fences** and their ancillary equipment shall be installed, operated and maintained in a manner that minimizes danger to persons, and reduces the risk of persons receiving an electric shock unless they attempt to penetrate the **physical barrier**, or are in the **secure area** without authority.

**Electric security fence** constructions that are likely to lead to the entanglement of persons shall be avoided.

Gates in **electric security fences** shall be capable of being opened without the person receiving an electric shock.

An **electric security fence** shall not be supplied from two separate **energizers** unless they are **type R security energizers** or **type S security energizers** configured and connected to operate in a **type R security energizer group** or **type S security energizer group**.

For any two separate **electric security fences**, each supplied from a separate **energizer**, the distance between the wires of the two separate **electric security fences** shall be at least 2,5 m. If this gap is to be closed, this shall be effected by means of a physical barrier of high voltage insulating material or earthed conducting material such that the two separate security fences cannot be contacted at the same time.

This gap can also be closed if the **electric security fences** are supplied by **type R security energizers** or **type S security energizers** that are part of a **type R security energizer group** or **type S security energiser group** configured and connected in accordance with the instructions.

A spacing of 2,5 m shall be maintained between uninsulated **connecting leads** supplied from separate **energizers**. This spacing may be less where

- the **connecting leads** are covered by insulating sleeving rated to at least 10 kV at mains frequency; or
- the **connecting leads** consist of insulated cables rated to at least 10 kV at mains frequency; or
- the **connecting leads** are powered by **energizers** that are part of a **type R security energizer group** or **type S security energizer group** configured and connected in accordance with the instructions.

Barbed wire or razor wire shall not be electrified by an **energizer**.

For earthing recommendations, follow the relevant national standard for **electric security fence** earthing. If this does not exist then follow the **energizer** manufacturer's instructions and recommendations.

The distance between any **electric security fence earth electrode** and other earth systems shall be not less than 2 m, except when associated with a graded earth mat.

Where possible, the distance between any electric **security fence earth electrode** and other earth systems should preferably be at least 10 m.

Exposed conductive parts of the **physical barrier** shall be effectively earthed.

Where an **electric security fence** passes below bare power line conductors, the highest metallic element shall be effectively earthed for a distance of not less than 5 m on either side of the crossing point.

**Connecting leads** that are run inside buildings shall be effectively insulated from the earthed structural parts of the building. This may be achieved by using insulated high voltage cable.

**Connecting leads** that are run underground shall be run in conduit of insulating material or else insulated high voltage cable shall be used. Care shall be taken to avoid damage to the **connecting leads** due to the effects of vehicle wheels sinking into the ground.

**Connecting leads** shall not be installed in the same conduit as the mains supply wiring, communication cables or data cables.

**Connecting leads** and **electric security fence wires** shall not cross above overhead power or communication lines.

Crossings with overhead power lines shall be avoided wherever possible. If such a crossing cannot be avoided, it shall be made underneath the power line and as nearly as possible at right angles to it.

If **connecting leads** and **electric security fence** wires are installed near an overhead power line, the clearances shall not be less than those shown in Table BB.3.

**Table BB.3 – Minimum clearances from power lines for electric security fences supplied from a security energizer group**

Power line voltage V	Clearance m
≤ 1 000	3
> 1 000 and ≤ 33 000	4
> 33 000	8

If **connecting leads** and **electric security fence** wires are installed near an overhead power line, their height above the ground shall not exceed 3 m.

This height applies to either side of the orthogonal projection of the outermost conductors of the power line on the ground surface, for a distance of

- 2 m for power lines operating at a nominal voltage not exceeding 1 000 V;
- 15 m for power lines operating at a nominal voltage exceeding 1 000 V.

**Electric security fences** shall be identified by prominently placed warning signs.

The warning signs shall be legible from the **secure area** and the **public access area**.

Each side of the **electric security fence** shall have at least one warning sign.

Warning signs shall be placed

- at each gate;
- at each access point;
- at intervals not exceeding 10 m;
- adjacent to each sign relating to chemical hazards for the information of the emergency services.

Any part of an **electric security fence** that is installed along a public road or pathway shall be identified at frequent intervals by warning signs securely fastened to the fence posts or firmly clamped to the fence wires.

The size of the warning sign shall be at least 100 mm × 200 mm.

The background colour of both sides of the warning sign shall be yellow. The inscription on the sign shall be black and shall be either

- the symbol of Figure BB.1, or
- the substance of “CAUTION: **Electric fence**”.

The inscription shall be indelible, inscribed on both sides of the warning sign and have a height of at least 25 mm.

Ensure that all mains operated, ancillary equipment connected to the **electric security fence circuit** provides a degree of isolation between the **fence circuit** and the supply mains equivalent to that provided by the **energizer**.

NOTE 2 Ancillary equipment that complies with the requirements relating to isolation between the **fence circuit** and the supply mains in Clauses 14, 16 and 29 of the standard for the **electric fence energizer** is considered to provide an adequate level of isolation.

Mains supply wiring shall not be installed in the same conduit as signalling leads associated with the **electric security fence** installation.

Protection from the weather shall be provided for the ancillary equipment unless this equipment is certified by the manufacturer as being suitable for use outdoors, and is of a type with a minimum degree of protection IPX4.

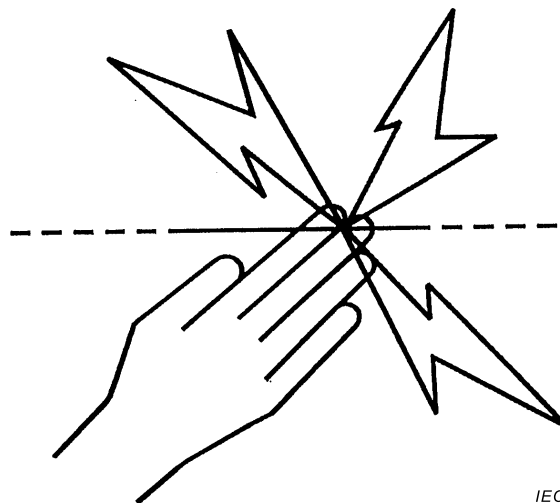

IEC

**Figure BB.1 – Symbol for warning sign**

## Annex CC (informative)

### Installation of electric security fences

#### CC.1 General

An **electric security fence** should be installed so that, under normal conditions of operation, persons are protected against inadvertent contact with **pulsed conductors**.

This requirement is primarily intended to establish that a desirable level of safety is present or is being maintained in the **physical barrier**.

When selecting the type of **physical barrier**, the likely presence of young children should be a factor in considering the size of openings and a risk assessment shall be made prior to installation.

#### CC.2 Location of electric security fence

The **electric fence** should be separated from the **public access area** by means of a **physical barrier**.

Where an **electric fence** is installed in an elevated position, such as on the inner side of a window or skylight, the **physical barrier** may be less than 1,5 m high where it covers the whole of the **electric fence**. If the bottom of the window or skylight is within a distance of 1,5 m from the floor or access level then the **physical barrier** need only extend up to a height of 1,5 m above the floor or access level.

#### CC.3 Prohibited zone for pulsed conductors

**Pulsed conductors** should not be installed within the shaded zone shown in Figure CC.1.

Where an **electric security fence** is planned to run close to a site boundary, the relevant government authority should be consulted before installation begins.

Typical **electric security fence** installations are shown in Figure CC.2 and Figure CC.3.

#### CC.4 Separation between electric fence and physical barrier

Where a **physical barrier** is installed in compliance with Clause CC.3, at least one dimension in any opening should be not greater than 130 mm and the separation between the **electric fence** and the **physical barrier** should be

- within the range of 100 mm to 200 mm or greater than 1 000 mm where at least one dimension in each opening in the **physical barrier** is not greater than 130 mm;
- less than 200 mm or greater than 1 000 mm where the **physical barrier** does not have any openings.

NOTE 1 These restrictions are intended to reduce the possibility of persons making inadvertent contact with the **pulsed conductors** and to prevent them from becoming wedged between the **electric fence** and the **physical barrier**, thereby being exposed to multiple shocks from the **energizer**.

NOTE 2 The separation is the perpendicular distance between the **electric fence** and the **physical barrier**.

## CC.5 Prohibited mounting

**Electric fence** conductors should not be mounted on a support used for any overhead power line.

## CC.6 Operation of electric security fence



The conductors of an **electric fence** should not be energized unless all authorized persons, within or entering the **secure area**, have been informed of its location.

Where there is a risk of persons being injured by a secondary cause, appropriate additional safety precautions should be taken.

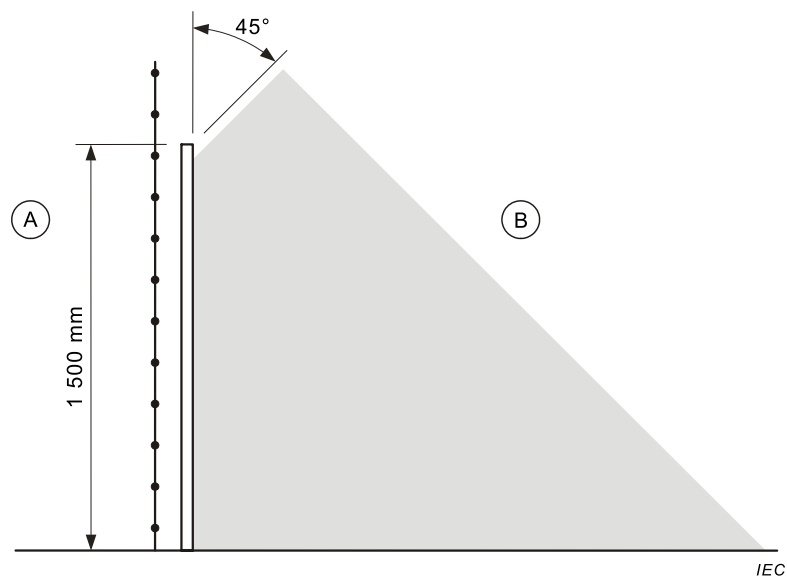
NOTE An example of a secondary cause is where a person can be expected to fall from a surface if contact is made with **pulsed conductors**.

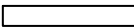

### Key

- A secure area
- B public access area
-  physical barrier
-  Prohibited area
-  electric security fence

**Figure CC.1 – Prohibited area for pulse conductors**

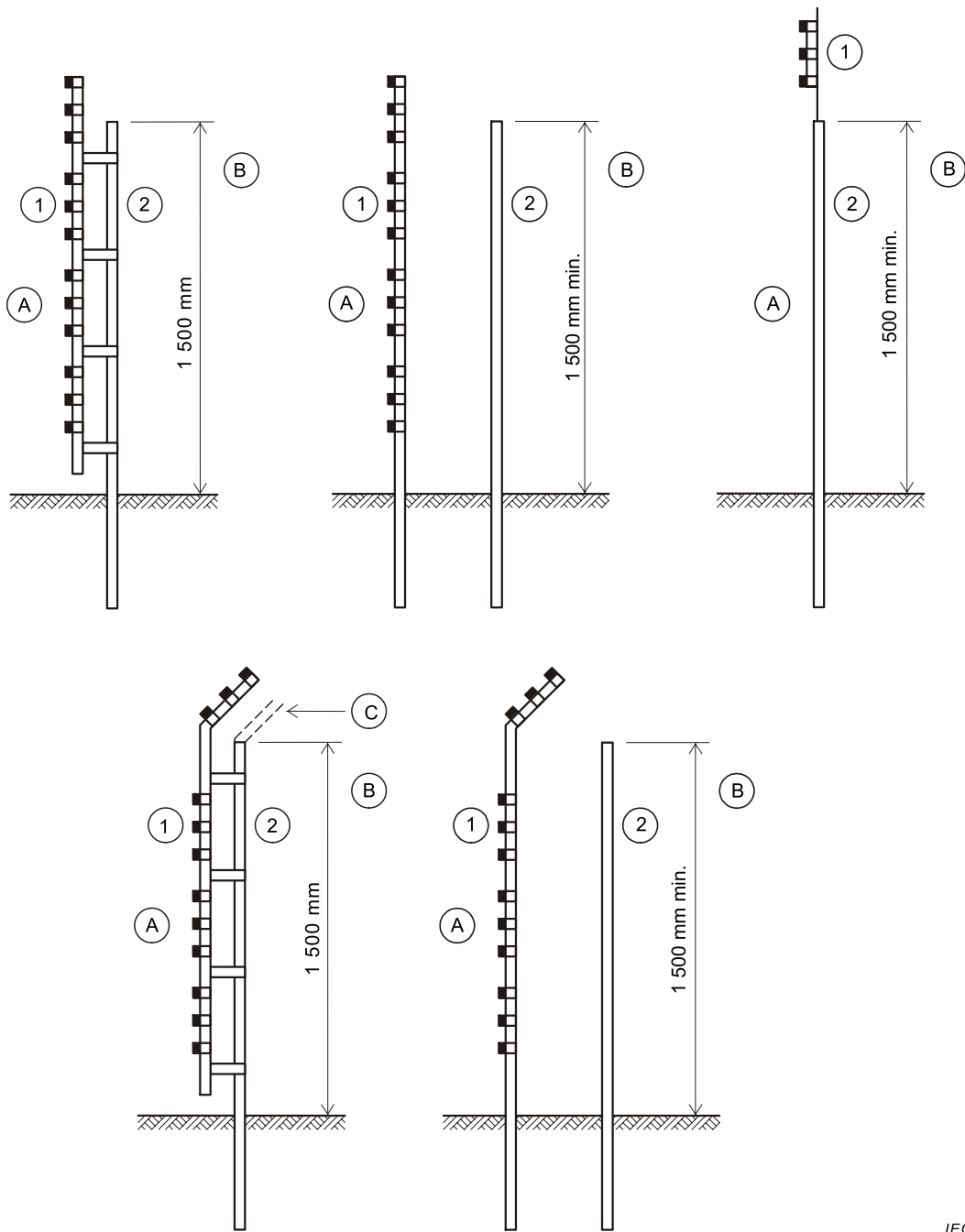

**Key**

- A **secure area**
- B **public access area**
- C barrier where required
- 1 **electric security fence**
- 2 **physical barrier**

**Figure CC.2 – Typical constructions where an electric security fence is exposed to the public**

IEC

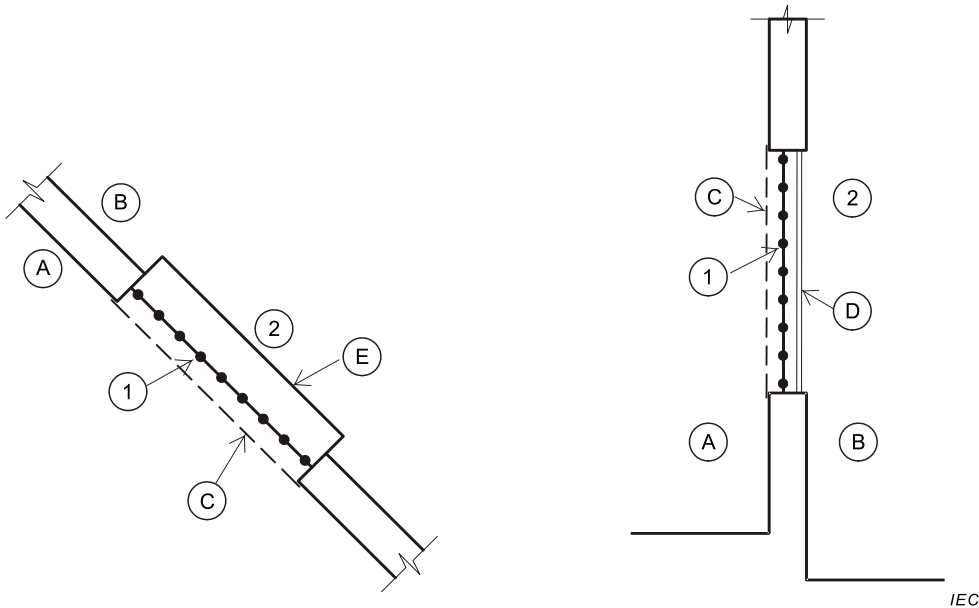

**Key**

- A **secure area**
- B **public access area**
- C barrier where required
- D glass window pane
- E skylight in roof
- 1 **electric security fence**
- 2 **physical barrier**

**Figure CC.3 – Typical fence constructions where the electric security fence is installed in windows and skylights**

## Bibliography

The bibliography of Part 1 is applicable except as follows.

*Addition:*

IEC 60335-2-86, *Household and similar electrical appliances – Safety – Part 2-86: Particular requirements for electric fishing machines*

IEC 60335-2-87, *Household and similar electrical appliances – Safety – Part 2-87: Particular requirements for electric animal stunning equipment*

---



INTERNATIONAL  
ELECTROTECHNICAL  
COMMISSION

3, rue de Varembé  
PO Box 131  
CH-1211 Geneva 20  
Switzerland

Tel: + 41 22 919 02 11  
Fax: + 41 22 919 03 00  
[info@iec.ch](mailto:info@iec.ch)  
[www.iec.ch](http://www.iec.ch)